



# RG6

Datasheet

22<sup>nd</sup> November 2019





**HENNLICH s.r.o.**  
Košťany nad Turcom 543,  
03841 Košťany nad Turcom

**Tel.:** 0903 632 570  
**E-mail:** robotizacia@hennlich.sk

[www.hennlich.sk](http://www.hennlich.sk)

## RG6

General Properties	Minimum	Typical	Maximum	Unit
Payload Force Fit 	- -	- -	6 13.2	[kg] [lb]
Payload Form Fit 	- -	- -	10 22.04	[Kg] [lb]
Total stroke (adjustable)	0 -	- -	160 6.3	[mm] [inch]
Finger position resolution	- -	0.1 0.004	- -	[mm] [inch]
Repetition accuracy	- -	0.1 0.004	0.2 0.007	[mm] [inch]
Reversing backlash	0.1 0.004	- -	0.3 0.011	[mm] [inch]
Gripping force (adjustable)	25	-	120	[N]
Gripping force deviation		±25		%
Gripping speed*	51	-	160	[mm/s]
Gripping time**	0.05	-	0.15	
Adjustable bracket tilting accuracy		< 1		°
Storage temperature	0 32		60 122	[°C] [°F]
Motor	Integrated, electric BLDC			
IP Classification	54			
Dimensions	262 x 212 x 42 10.3 x 8.3 x 1.6			[mm] [inch]
Weight	1.25 2.76			[kg] [lb]

\*See table on the next page

\*\* based on 8mm total movement between fingers. The speed is linearly proportional to the force. For more details see speed table on next page.

Operating Conditions	Minimum	Typical	Maximum	Unit
Power supply	20	24	25	[V]
Current consumption	70	-	600*	[mA]
Operating temperature	5 41	- -	50 122	[°C] [°F]
Relative humidity (non-condensing)	0	-	95	[%]
Calculated MTBF (operating life)	30.000	-	-	[Hours]

\*Current spikes up to 3A (max 6mS) may occur during the release action.

## RG6 Gripping Speed Graph

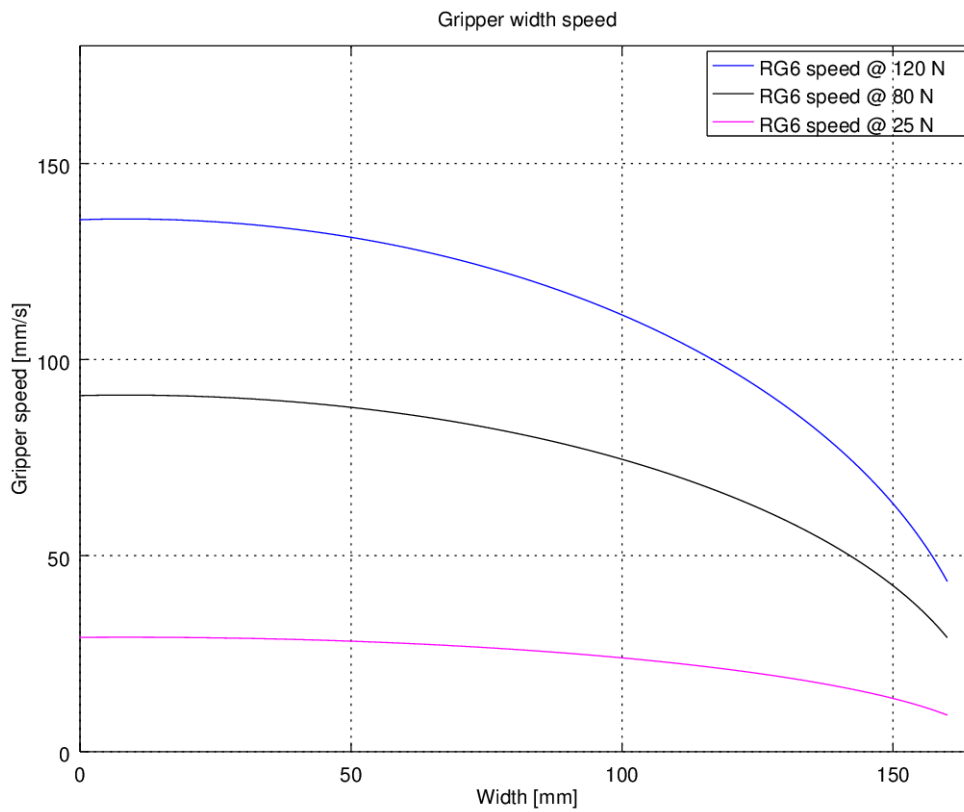

## RG6 Work Range

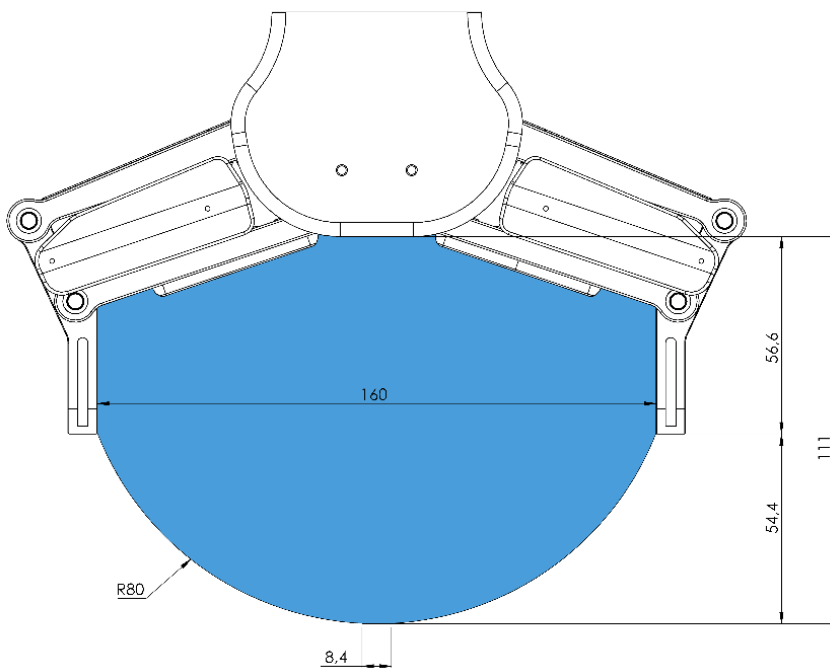

Gripping on long objects can unintentionally activate the Safety switches. The maximum workpiece height (calculated from the end of the fingertips) is dependent on the gripping width (w). For various width values the height (h) limit is given below:

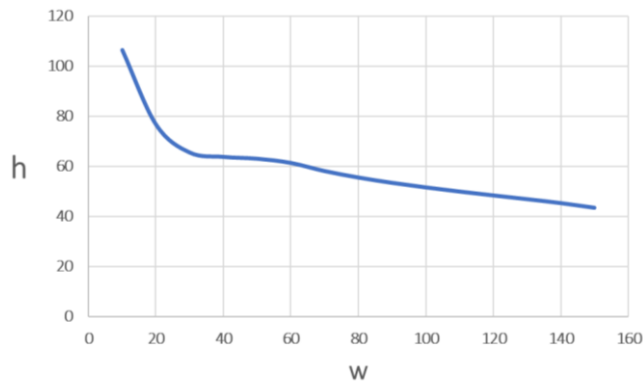

## Fingertips

The standard fingertips can be used for many different workpieces. If custom fingertips are required, they can be made to fit the Gripper's fingers according to the dimensions (mm) shown below:

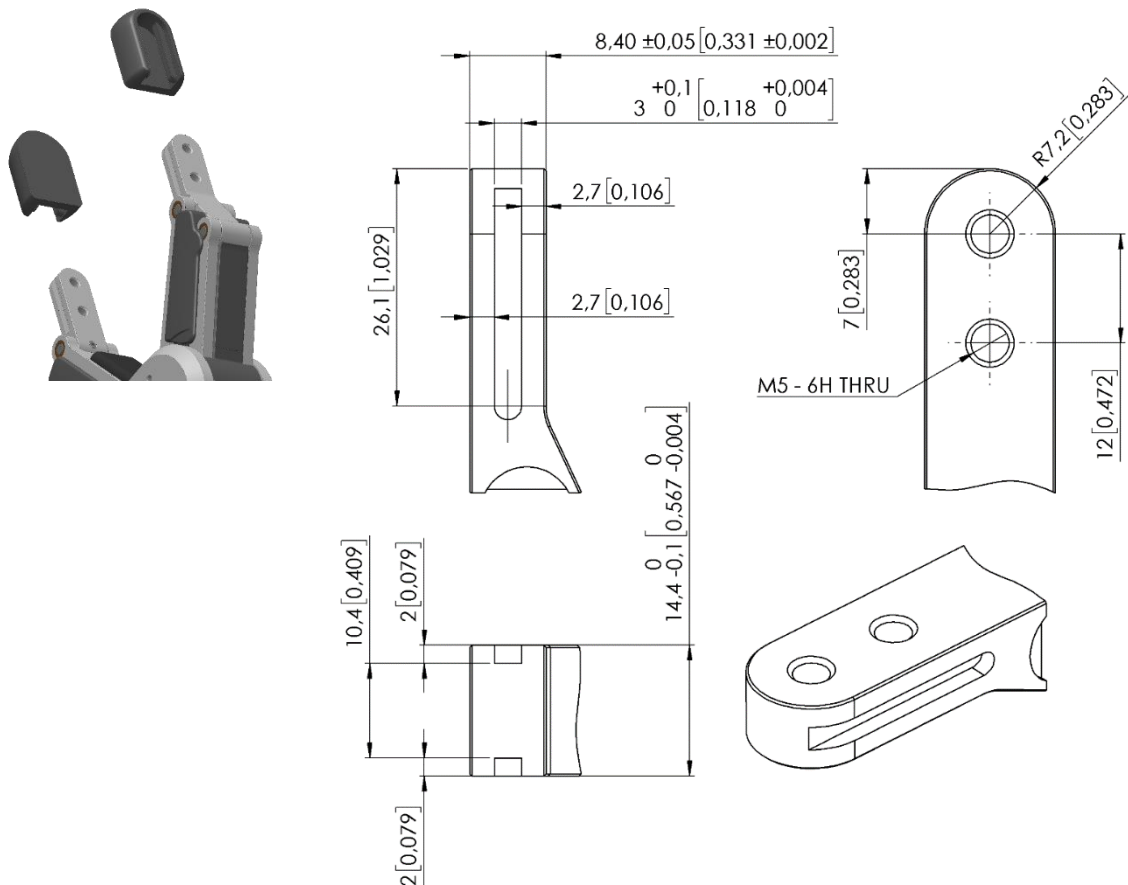

# RG6

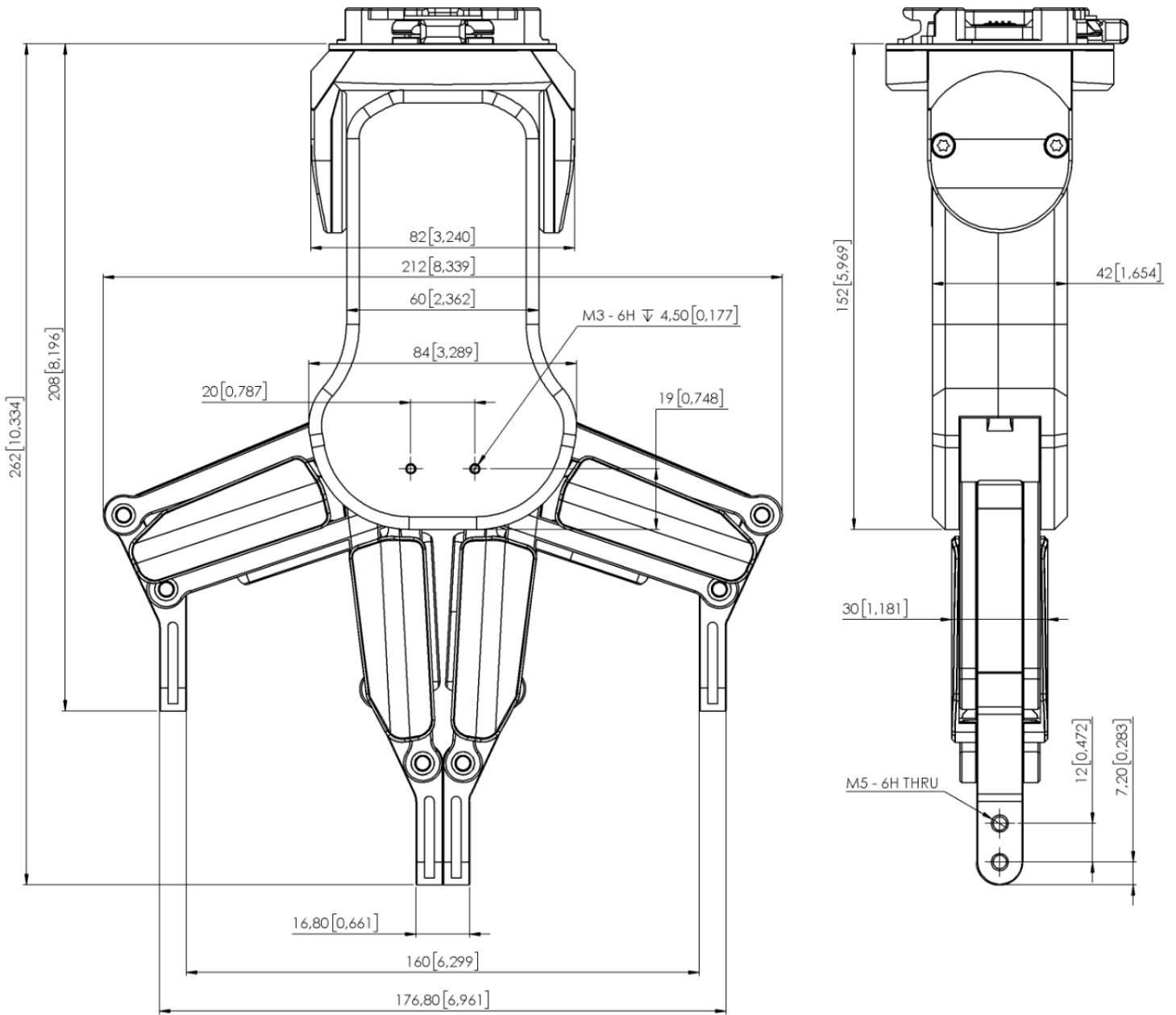

All dimensions are in mm and [inches].



**HENNLICH s.r.o.**  
Košfany nad Turcom 543,  
03841 Košfany nad Turcom

**Tel.:** 0903 632 570  
**E-mail:** robotizacia@hennlich.sk

[www.hennlich.sk](http://www.hennlich.sk)