



# GECKO GRIPPER

Datasheet

22<sup>nd</sup> November 2019



**HENNLICH s.r.o.**  
Košťany nad Turcom 543,  
03841 Košťany nad Turcom

**Tel.:** 0903 632 570  
**E-mail:** robotizacia@hennlich.sk

[www.hennlich.sk](http://www.hennlich.sk)

## Gecko

General Properties					Unit
<b>Gripper</b>					
Workpiece Material	<b>Polished Steel</b>	<b>Acrylic</b>	<b>Glass</b>	<b>Sheet Metal</b>	
Maximum payload (x2 safety factor)	6.5 14.3	6.5 14.3	5.5 12.1	5.5 12.1	[kg] [lb]
Preload required for max adhesion	140				[N]
Detachment time	300				[msec]
Holds workpiece on power loss?	yes				
<b>Pads</b>					
Change-out interval	150 000 to 200 000 cycles for HIGH preload 200 000 to 250 000 cycles for LOW preload				[cycles]
Manual Cleaning	Isopropyl alcohol and lint free cloth				
Robotic cleaning system	Cleaning Station				
Robotic cleaning interval and % recovery	Refer to Cleaning Station User Guide				
<b>Sensors</b>					
	Pre-load sensor		Ultrasonic Range sensor		
Range	45 [N] 9 [lb]	140 [N] 31 [lb]	0	260 [mm] 10 [inch]	[N][mm] [lb][inch]
Error	7%		2%		
IP Classification	42				
Dimensions (HxW)	187 x 146 7.3 x 5.7				[mm] [inch]
Weight	2.85 6.3				[kg] [lb]



### NOTE:

Avoid preloading the gripper with an inverted robot or in non-vertical loading conditions. If preloaded whilst inverted, preload sensor will not meet typical performance standards.

Operating Conditions	Minimum	Typical	Maximum	Unit
Temperature	0 32	- -	50 122	[°C] [°F]
Surface Characteristics*	Matte finish	Highly polished	-	

\* Smoother surfaces require less preload force for a desired payload force.

Specification or Feature	Target value
Parts Presence Sensing	Yes (Ultrasonic)
Pad Material	Proprietary silicone blend
Wear Properties	Depends on surface roughness and preload
Pad Attachment Mechanism	Magnetic
Change-out interval	150000 – 200000 for HIGH PRELOAD 200000 – 250000 for LOW PRELOAD
Cleaning system	Cleaning station
Cleaning interval and % recovery	See Cleaning Station Manual

### Effectiveness on Different Materials

The Gecko Gripper is best suited for smooth, low surface roughness substrates that are generally flat, stiff, and rigid. For other materials, the Gecko Gripper's effectiveness drops depending on the stiffness and roughness of the picking surface. The table below shows a relationship between rigid and flexible substrates, surface finish, payload and the required preload to pick up said substrate. For example, if the customer knows that their part/substrate is rigid, with a mirror-like finish and weighs 2kg, the preload required to pick up the part/substrate is a medium-level preload.

Flexibility	Surface finish	Payload (kg)	Required Preload
Rigid	Mirror-like finish	0 to 2	Low
		2 to 4	Medium
		4 to 6	High
	Smooth	0 to 2	Medium
		2 to 4	High
		4 to 6	N/A
	Matte	0 to 2	High
		2 to 4	N/A
		4 to 6	N/A
Flexible	Mirror-like finish	0 to 2	Medium
		2 to 4	High
		4 to 6	N/A
	Smooth	0 to 2	High
		2 to 4	N/A
		4 to 6	N/A
	Matte	0 to 2	N/A
		2 to 4	N/A
		4 to 6	N/A

To further elaborate the significance between preload and payload, the table below shows a visual matrix that displays the capability of the Gecko Gripper to pick up different materials with varying stiffness and roughness, at three different preload values (low 40N, medium 90N, high 140N).



Stiffness	Roughness	Example of material	Preload - 140N						Preload - 90N						Preload - 40N					
			Payload [kg]						Payload [kg]						Payload [kg]					
			0.1	0.5	1	2	4	6	0.1	0.5	1	2	4	6	0.1	0.5	1	2	4	6
1	1	Mylar	✓	✓	✓	*			✓	✓	*			✓	*					
5	1	Transparency sheet	✓	✓	✓	✓	*		✓	✓	*			✓	*					
10	1	Polished mirror-like steel, solar panel	✓	✓	✓	✓	✓	✓	✓	✓	✓	✓	✓	*	✓	✓	✓	✓	*	
1	5	Cling film, ziploc bags	✓	✓	*				✓	*				✓	*					
5	5	Glossy cardboard (cereal box)	✓	✓	*				✓	*				✓	*					
10	5	Printed circuit board	✓	✓	✓	✓	*		✓	✓	*			✓	*					
1	10	Laminating plastic / film	*																	
5	10	Corrugated cardboard																		
10	10	Sandblasted aluminum																		

✓ the gripper can easily pick up the material

\* the gripper can pick up the material in some cases (requires caution and testing to verify)

**Nothing** the gripper cannot pick up this type of material.



**NOTE:**

This table is to be utilized as a guide to better understand the payload capacity and substrate type for the Gecko Gripper.

The criteria for stiffness and roughness is a basic scale from 1-10, here are the benchmarks used to determine the values.

Stiffness	Description	Example
1	Flexible	Fabric
5	Semi-flexible	Cardboard
10	Stiff	Metal

Roughness	Description	Example	RMS Value
1	Polished/Smooth	Polished Metal	0.1 micron
5	Textured	Carboard	7 microns
10	Rough	Sandblasted Metal	28 microns



**HENNLICH s.r.o.**

Košfany nad Turcom 543,  
03841 Košfany nad Turcom

**Tel.:** 0903 632 570

**E-mail:** robotizacia@hennlich.sk

[www.hennlich.sk](http://www.hennlich.sk)

## Gecko

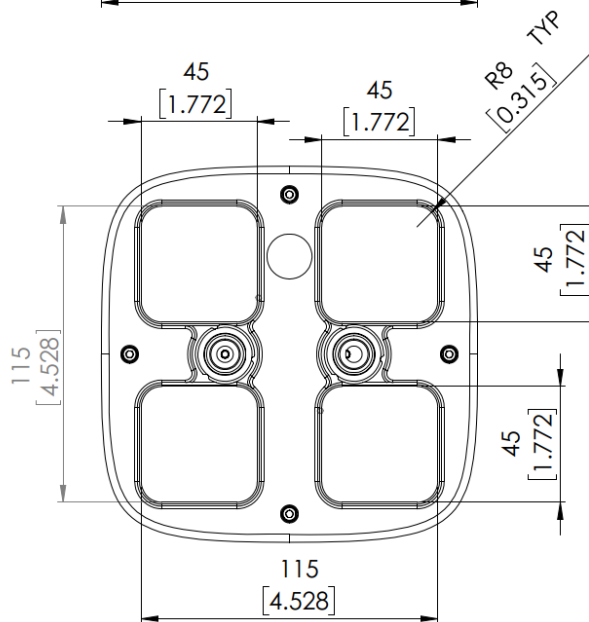
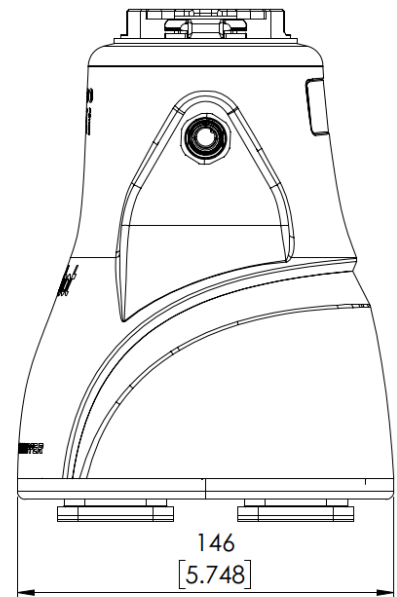
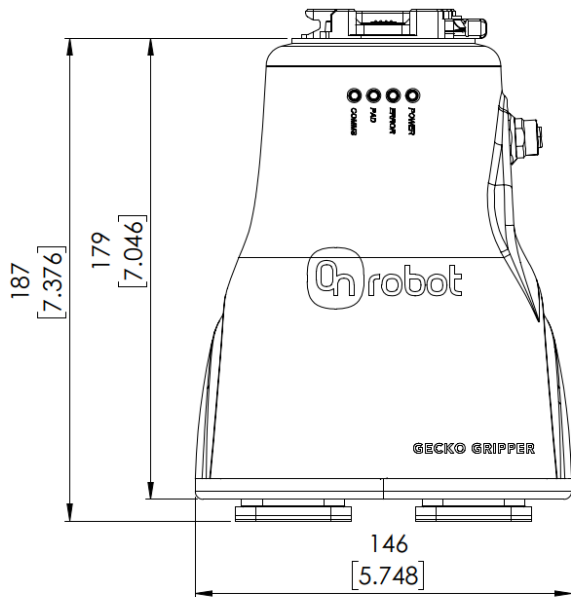

All dimensions are in mm and [inches].



**HENNLICH s.r.o.**  
Košťany nad Turcom 543,  
03841 Košťany nad Turcom

**Tel.:** 0903 632 570  
**E-mail:** robotizacia@hennlich.sk

[www.hennlich.sk](http://www.hennlich.sk)