

Product Information

Flow Transmitter CF



- Flow measurement device using the vortex measurement principle
- High precision
- High stability to excessive flow rates
- No moving parts
- Rapid installation and removal thanks to clamp fastening
- Various connections using building block system

Characteristics

A narrow triangular body (1), which goes through the complete cross-section of the measurement pipe, creates vortices in the medium when there is a flow (Kármán vortex street, vortex effect). The frequency of the vortex is proportional to the flow, and is detected using a piezo-sensor (2), which lies behind the triangular body. The complete unit, vortex body, and detector are designed as a plug-in unit (3), and are inserted into the pipe. Here, a lightning fast separation between measurement pipe and the complete measurement unit is possible.

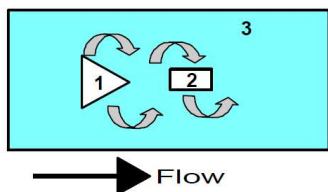

The frequency signal is made available to the output via a push-pull transistor stage, and is resistant to short circuits and reversed polarity protected. The push-pull output can as desired be connected as a PNP or an NPN output.

Technical data

Sensor	vortex principle	
Nominal width	DN 8..25	
Process connection	female thread G 1/4..G 1 (others available on request)	
Metering ranges	0.9..150 l/min for details, see table "Ranges"	
Measurement accuracy	up to 50 % of full scale value: ±1 % of measured value from 50 % of full scale value: ±2 % of measured value	
Pressure resistance	PN 10 bar	
Media temperature	0..60 °C	
Ambient temperature	-20..+70 °C	
Materials medium-contact	Housing	CW614N plated, 1.4571 or POM GF
	Connection	CW614N plated, 1.4571 or POM
	Detector	ETFE PA6T6I 40 % GF
	Seal	EPDM
Supply voltage	10..30 V DC	
Current consumption at rest	approx. 20 mA (without load)	
Signal output	transistor output "push-pull" (resistant to short circuits and polarity reversal) I _{out} = 100 mA max. for output frequencies see table "Ranges"	
Electrical connection	for round plug connector M12x1, 4-pole	
Ingress protection	IP 67	
Weight	see table "Dimensions"	
Conformity	CE	

Ranges

G	Types	Range l/min H ₂ O	Frequency Hz
G 1/4	CF-008GM.	0.9.. 15 l/min	approx. 34..437
G 3/8	CF-010GM.	1.8.. 32 l/min	approx. 24..382
G 1/2	CF-015GM.	3.5.. 50 l/min	approx. 19..269
G 3/4	CF-020GM.	5.0.. 85 l/min	approx. 14..229
G 1	CF-025GM.	9.0..150 l/min	approx. 12..202

... professional Instruments "MADE IN GERMANY"

Product Information

Wiring

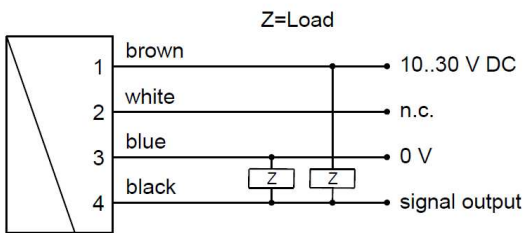

Connection example: PNP NPN

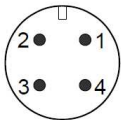

Before the electrical installation, it must be ensured that the supply voltage corresponds with the data sheet. It is recommended to use shielded wiring.

Dimensions

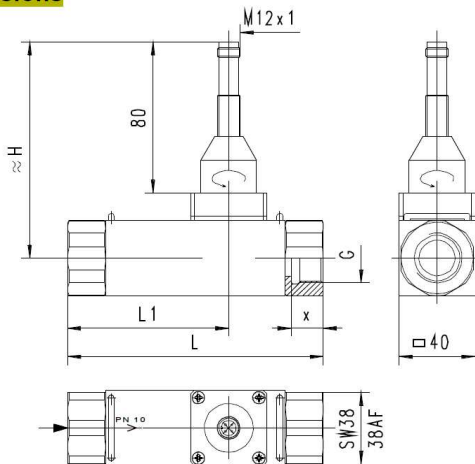

G	DN	Types	H	L	L1	X	Weight* kg
G 1/4	DN 8	CF-008GM	113	125	69	12,5	1.45
G 3/8	DN 10	CF-010GM	111	100	50	14,5	1.10
G 1/2	DN 15	CF-015GM	113				1.10
G 3/4	DN 20	CF-020GM	115	135	85	16,5	1.50
G 1	DN 25	CF-025GM	117	155	95	18,5	1.30

*Weight details for metal model. Plastic models available on request

Handling and operation

Installation

The vortex flow meter requires a run-in length of 5..10 x D in order to achieve its specified accuracy. If deposits are to be expected, sensor and electronics should not be installed underneath. It should be ensured that the sensor is installed in the direction of the flow arrow. If the sensor is to be cleaned, the clamps should be released, and the device removed (the pipe should be pressure-free for this). It should be ensured during cleaning that the oscillating vortex body is not exposed to impact (in the moulded part there is a sensitive piezo-ceramic sensor, which can break).

Ordering code

CF- 1. 2. 3. 4. 5. 6. 7. 8.

○ = Option

1. Nominal width	
008	DN 8 - G 1/4
010	DN 10 - G 3/8
015	DN 15 - G 1/2
020	DN 20 - G 3/4
025	DN 25 - G 1
2. Process connection	
G	female thread
3. Connection material	
M	CW614N plated
K	○ 1.4571
P	○ POM
4. Body material	
M	CW614N plated
K	1.4571
P	○ POM GF
5. Metering range	
015	0.9.. 15 l/min
032	1.8.. 32 l/min
050	3.5.. 50 l/min
085	5.0.. 85 l/min
150	9.0..150 l/min
6. Sealing material	
E	EPDM
7. Signal output	
F	frequency output (push-pull)
8. Electrical connection	
S	for round plug connector M12x1, 4-pole

Accessories

- Cable/round plug connector (KB...) see additional information "Accessories"
- Counter EEZ-904
- Converter/counter OMNI-TA

... professional Instruments "MADE IN GERMANY"