



High impact tank cleaning machine

»IntenseClean Hygienic«

Series 5TA/5TB



- Gear-controlled
- Particularly powerful solid jets
- Operating pressures up to 15 and 25 bar possible

Materials:

316L SS,
632 SS,
PEEK, PTFE,
Zirconium oxide, EPDM

Max. temperature:

95 °C

Recommended operating pressure:

5 bar

Installation:

Operation in every direction possible

Filtration:

Line strainer with a mesh size of 0.2 mm/80 mesh

Bearing:

Ball bearing

Weight:

5TA: 0,9 kg
5TB: 4.0 kg

Rotation monitoring sensor:





Sensor compatible, please ask for more information.

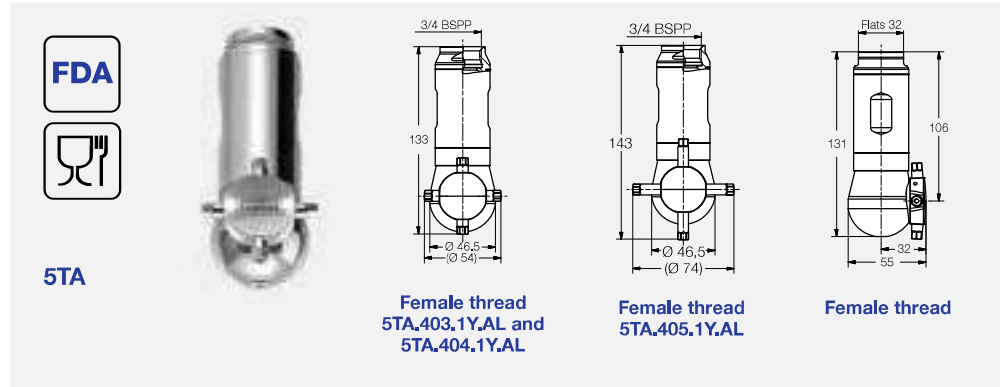

ATEX version on request





Spray angle 	Ordering no. Type	E Ø [mm]	Number, Ø Nozzles [mm]	V̇ [l/min]				Max. tank diameter [m]
				p [bar] (p _{max} = 15 bar)				
				2	5	10	at 40 psi [US gal./ min]	
360° 	5TA.403.1Y.AL	1.5	4 x 3.0	25	40	56	7.8	12.0
	5TA.404.1Y.AL	1.5	4 x 4.0	35	55	78	10.9	12.5
	5TA.405.1Y.AL	1.5	4 x 5.0	50	79	112	15.5	13.0

E = narrowest free cross-section · Slip-on connection on request

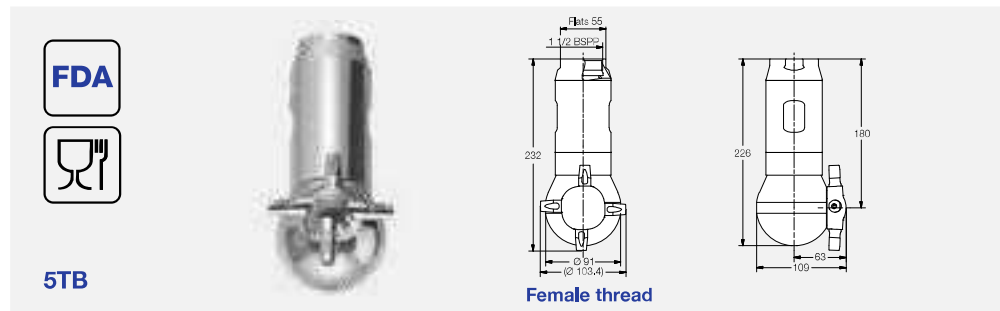
The maximum tank diameter shown above applies for the recommended operating pressure and is indicative only. The cleaning result is also affected by the type of soiling.



Spray angle 	Ordering no. Type	E Ø [mm]	Number, Ø Nozzles [mm]	V̇ [l/min]				Max. tank diameter [m]
				p [bar] (p _{max} = 25 bar)				
				2	5	10	at 40 psi [US gal./ min]	
360° 	5TB.406.1Y.AS	6.0	4 x 6.0	107	169	239	33.1	14.0
	5TB.407.1Y.AS	6.0	4 x 7.0	135	213	302	41.9	14.0
	5TB.408.1Y.AS	6.0	4 x 8.0	165	261	369	51.2	15.0

E = narrowest free cross-section

The maximum tank diameter shown above applies for the recommended operating pressure and is indicative only. The cleaning result is also affected by the type of soiling.