

➤ Tangential-flow hollow cone nozzles

Series 350

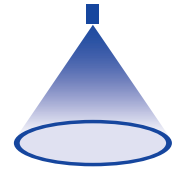

Features:

- High performance nozzle for humidification of air
- Very narrow droplet spectrum
- Extremely uniform liquid distribution over the entire spray pattern
- Quick-release clamp unit available for pipe mounting

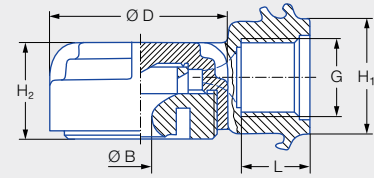
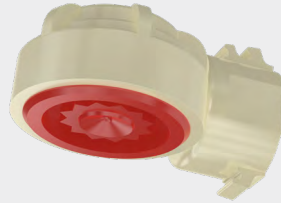

Applications:

- Foam control
- Dust control
- Surface spraying
- Absorption

Series 350

G	Dimensions [mm]				Weight [g]	P _{max} [bar]
	H ₁	H ₂	L	Ø D		
3/8 BSPP	24.0	20.0	14.0	37.0	37.0	20.0

Spray angle	Ordering no.		Bore diameter B [mm]	Narrowest free cross section Ø [mm]	V̇ water [l/min]							Spray diameter D [mm] (at p = 2 bar)	
	Type	Mat. no.			p [bar]							 H = 250 [mm] H = 500 [mm]	
		56			0.5	1.0	2.0	3.0	5.0	7.0	10.0		
130°	350.368	●	1.55	0.70	0.32	0.45	0.63	0.77	1.00	1.18	1.41	950	1,250
	350.608	●	5.00	1.40	1.58	2.23	3.15	3.86	4.98	5.89	7.04	990	1,950

Accessories:

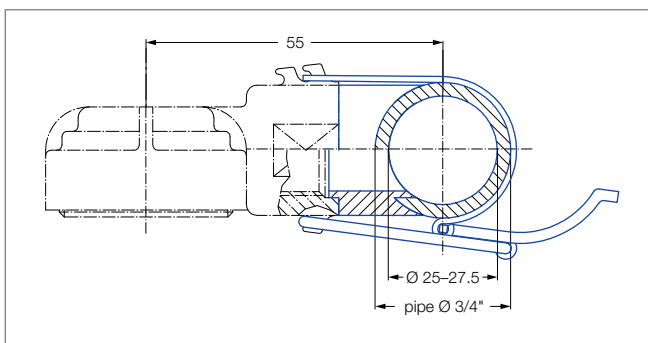

Recommended bore diameter 18 mm.

Quick-release clamp unit: Ordering no. 035.030.15.05.00.0.

Consisting of: Stainless steel clamp, polyurethane gasket.

Conversion formula for this series: $\dot{V}_2 = \dot{V}_1 \cdot \sqrt{\frac{p_2}{p_1}}$

Ordering Type + Material no. = Ordering no.
example: 350.368 + 56 = 350.368.56

Assembly accessories can be found in Chapter 9 "Accessories".