



Spillback Nozzle Lances



Efficient Gas Conditioning made by Lechler

For over 125 years, Lechler has pioneered developments in spray technology for all industries, designing, developing and manufacturing products of outstanding reliability and performance. All accompanied by expert advice based on a thorough knowledge gained through experience in providing both conventional and innovative solutions.

Wherever you are, Lechler seeks to establish a partnership, helping you to enhance product quality through the application of advanced fluids engineering expertise.



From development, through manufacture to installation, Lechler products are subject to continuous quality management. State of the art test and inspection methods, often in excess of our ISO 9001 certification, reliability and longevity of Lechler spray nozzles and systems.



VarioCool® system

Lechler offers you complete gas conditioning systems **VarioCool®**, including nozzle lances, pumps, regulation units and electronic controls. As the only manufacturer worldwide Lechler supplies gas conditioning systems equipped with spillback nozzle lances as well as twin fluid nozzle lances. The „coupled with the engineers“ experience gained through numerous installations worldwide, enables tailor-made solutions to be designed and implemented.

- **Complete system from one source with guarantees on system and process.**
- **Guarantee on full evaporation.**
- **Lechler offers spillback and twin fluid lances.**
- **Extensive engineering support, e.g. gas cooling calculations.**
- **Modern measuring technology guarantees high product quality.**



Pump and regulation unit

Applications

Lechler **VarioCool**[®] gas conditioning systems have been used successfully in the following processes of gas treatment:

Cooling / Humidifying (conditioning) in front of ESP

as an example in waste incinerators, in cement works, in coal fired power stations in front of ESP/baghouse.

DeNox Process

In accordance with the SNCR (high temperature DeNox process) or SCR (low temperature DeNox process with catalytic converter) technology e.g. in municipal waste incinerators and power stations.

Spray dry FGD

(for drying of reacted limestone slurry), such as in municipal waste incinerator plants.

Spray adsorption

as in flue gas desulphurization sections of smaller block type coal fired power stations.

Atomizing of residues into burning chambers,

for instance in waste and special waste incinerator plants.

Measuring technology

For the design of an engineered system or plant it is necessary to obtain a multitude of nozzle specific data that permits exact statements about flow rate, pressure, spray width, droplet size and droplet velocity. In order to measure these parameters

Lechler uses the most modern measuring technology which was partly developed by Lechler. Data from our measuring laboratory is available on request. A further service offered by Lechler is our series of gas cooling calculations.



Computer aided data capture

Gas Conditioning with Lechler Spillback Nozzle Lances

Anywhere where exhaust gases have to be cooled in conditioning towers before they are conveyed into the electrostatic precipitators, such as

- cement industry
- refuse incineration plants
- sponge iron plants
- blast furnaces and oxygen vessels in steel plants
- glass plants the varying temperatures and changing volumes of the exhaust gases pose a problem:

How to atomize a variable flow of liquid with consistent fineness?

Lechler Spillback Nozzle Lances provided the answer.

The liquid is always pumped to the nozzle at a constant high pressure regardless of the sprayed volume.

All the nozzles which atomize by liquid pressure only are fed from the same supply line with a joint return pipe to the reservoir. The flow rate of the sprayed liquid is only controlled by a motorised regulating valve in the joint return line. Maximum injection occurs when the return line is closed.

The feed pressure in the supply line remains always constant. The turn down ratio is 10:1 (max.: min. flow rate with no change of number of nozzles) maintaining a constant fine atomization over the full range.

The Lechler Spillback Nozzle System ensures good process results due to precise cooling of the exhaust gases with the optimum of cooling liquid.

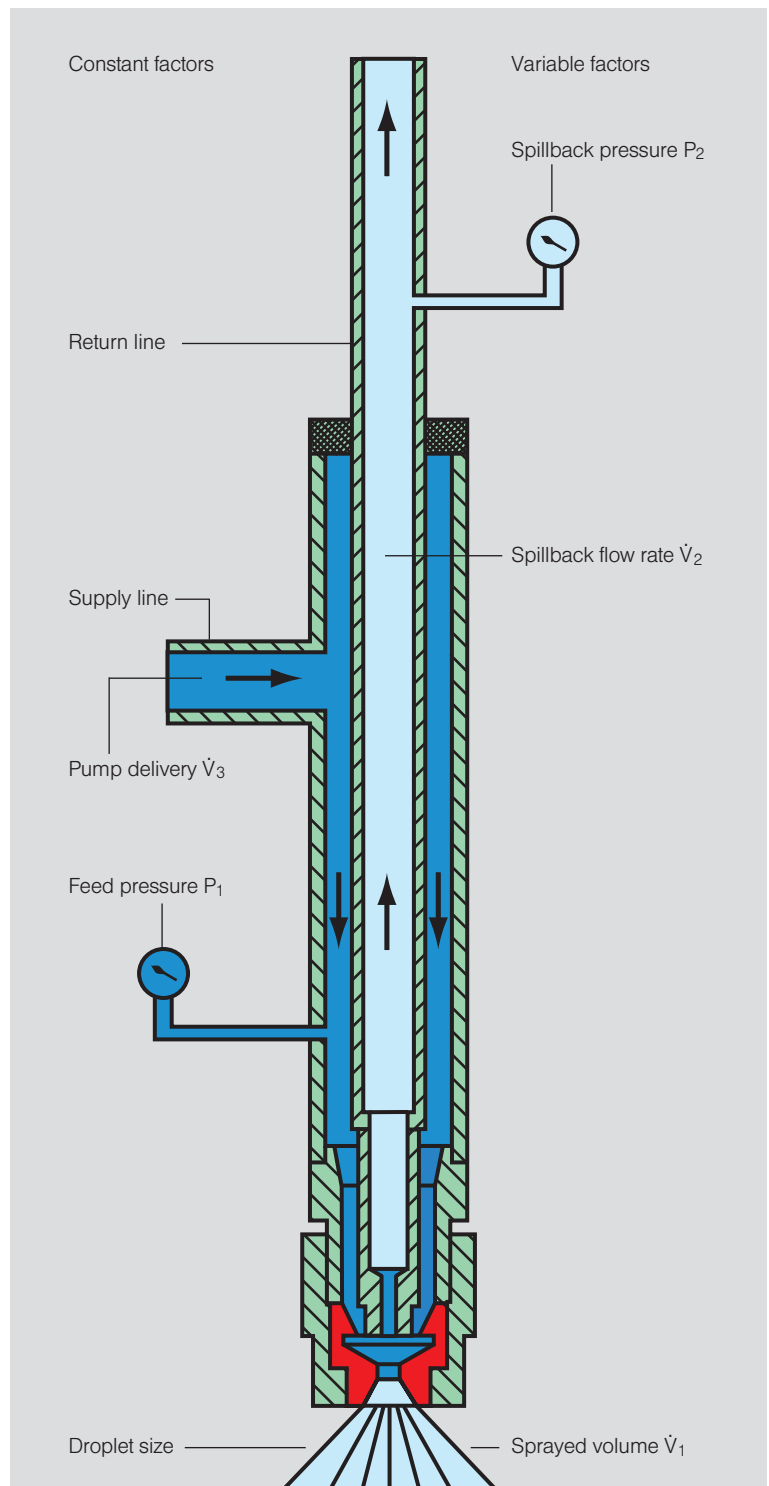

Pressure-Flow Diagram

The pressure flow rate diagram shows the quantity of supply flow rate atomized in relation to the return pressure (P_2). It also shows what the return pressure must be in order to obtain a specific spray flowrate \dot{V}_1 at constant feed pressure. Maximum atomized flow rate \dot{V}_{1max} is attained when the return is completely closed. As the return is opened, the flow rate of atomized liquid reduces. At part load, the sum of the atomized liquid and the return

flow is greater than the maximum atomization flow.

Consequently, the capacity of the h. p. supply pump must be correspondingly higher (approx. 40 - 50 %). The delivery curve of the pump should be as flat as possible in the working range.

An accurately matched control characteristic must be chosen for the regulating valve in order to guarantee the turn down ratio of 10 : 1.

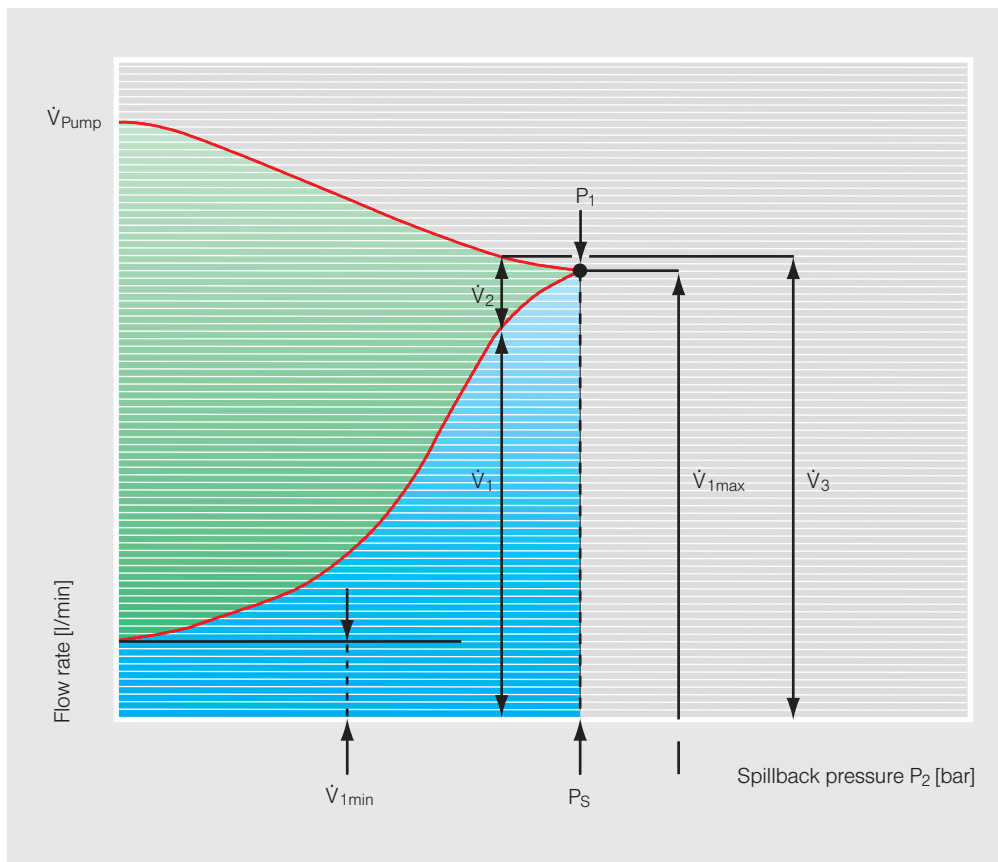

- \dot{V}_1 = Sprayed volume
- \dot{V}_{1max} = Max. sprayed volume (return line closed)
- \dot{V}_{1min} = Min. sprayed volume (return line completely open)
- \dot{V}_2 = Spillback flow rate
- \dot{V}_3 = Pump delivery
- \dot{V}_{Pump} = Pump delivery per nozzle
- P_1 = Constant feed pressure
- P_2 = Spillback pressure
- P_S = Spillback pressure at \dot{V}_{1max} (P_{max} for control valve)
- Turn down ratio = $\dot{V}_{1max} / \dot{V}_{1min}$.

Examples of configuration

Lechler Spillback Nozzle Lances of this type can be delivered with various spray positions of the nozzles. The compact construction allows easy mounting. The robust construction made from high quality stainless steel provides significant safe operation of the spray lance. Lechler Spillback Nozzle Lances are delivered as a complete spray unit. All components are designed to exactly match each other. This ensures minimum down time when installing and connecting.

Advantages:

- Compact construction
- Robust design
- Maintenance friendly construction
- Functional and safe operation

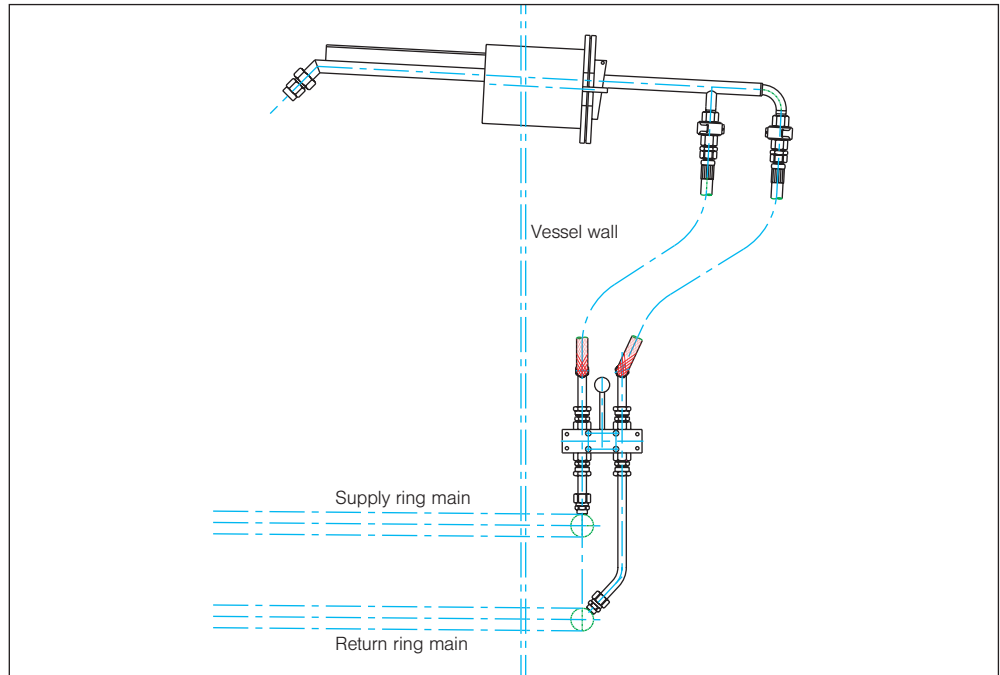

Spillback Nozzle Lance with accessories

The nozzle lance illustrated is designed with a **compact shield**. This shield reduces the flow resistance in the gas duct compared with the lance itself. At high gas velocity in particular, this results in an improved process result. The air barrier protects the nozzle from clogging and protects the interior nozzle lance against corrosion and overheating. The conical design of the front barrier air cap effectively ensures that the nozzle is evenly surrounded by an air barrier. This guarantees reliable, low-maintenance operation. The front barrier air cap can be quickly dismantled in order to inspect the nozzle.

Advantages:

- Robust and compact design
- High safety in operation

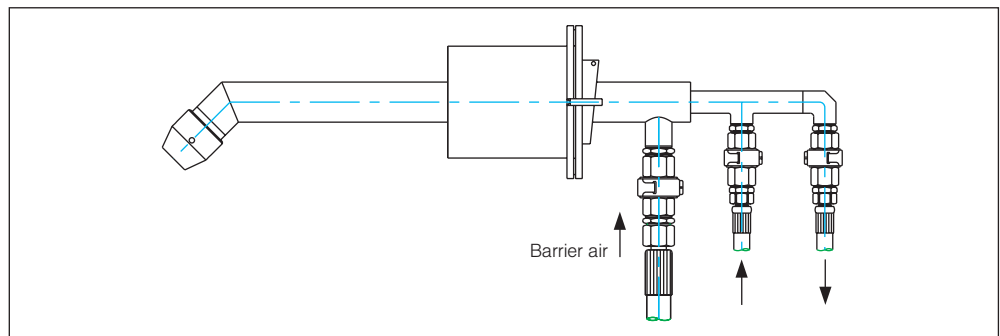

Spillback Nozzle Lance with small shield and barrier air

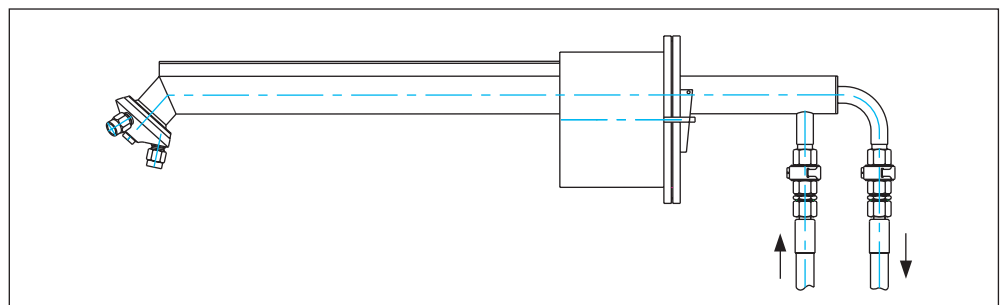

Spillback Cluster Lance

Examples of configuration

If the object is to atomize relatively large quantities of cooling water, spillback nozzle lances with cluster head can be installed as an alternative to several individual lances at different levels. The controllable atomization rate is 10:1. Each multiple sprayer can comprise 3, 4 or 6 nozzles. Spillback nozzle lances of this type are available in different lengths for axial, ascending and descending atomizing cones (45°).

Main merits

- robust, compact design
- wedge-flanging for easy installation and removal

Materials:

The standard material is stainless steel 316/1.4571. High alloy steels, such as chromium-nickel steels (Hastelloy) are also available for special processes. Lances made from plastic materials, such as PVC, PVDF, PTFE and temperature resistant FRP have proved to be highly efficient for some special applications.

Standard delivery scope:

- Pressure resistant and flexible hoses
- Shut off valve
- Mounting devices, coupling devices
- Special accessories up to complete systems including control units (see page 11).

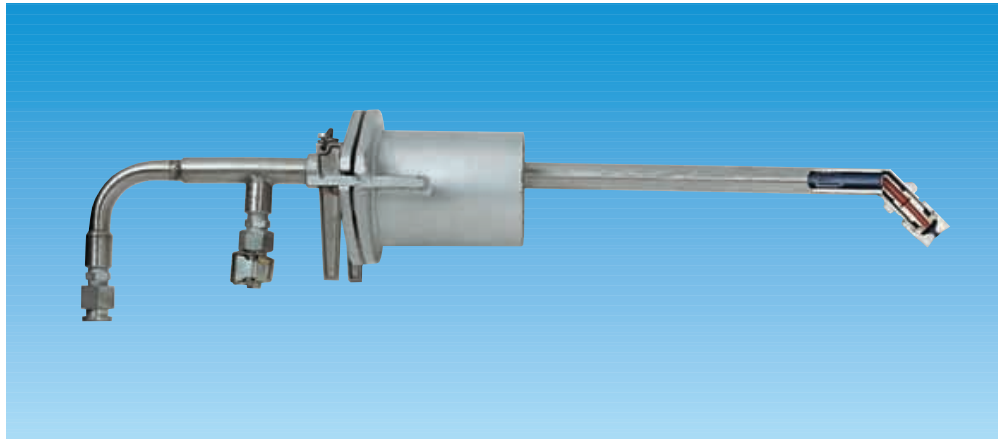

Spillback Nozzle Lance

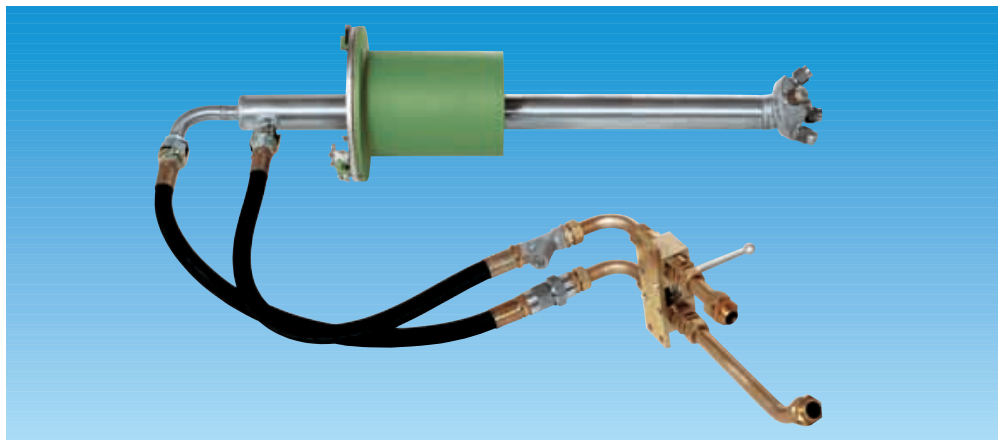

Spillback Cluster Lance

Selecting the nozzles

The choice of the nozzle and its flow rate depends on the total flow of liquid to be sprayed and on the type and number of lances respectively.

There are six standard spill-back nozzle sizes available. All nozzle sizes do fit on every lance. The nozzles are interchangeable. However, cluster lances should always be equipped with only one nozzle size on a particular lance. A minimum feed pressure of 30 bars is recommended. The maximum allowable feed pressure for the standard lances is 50 bars.

Materials available

Component	Material
Insert	- 316 SS
	- SS, hardened
Gasket	- 316 SS
Swirl disc	- 316 SS, hardened
	- SS, hardened
Mouth piece	- 316 SS, hardened
	- Titan
	- Hastelloy
	- SS, heat resistant
	- Ceramic
	- Tungsten carbide
Housing	- 316 SS
	- Hastelloy
	- 314 SS

Flow rates of nozzles for spillback nozzle lances

Nozzle size	Nozzle type	Flow V (l/min) at pressures p (bar)					
		25 bar	30 bar	35 bar	40 bar	45 bar	50 bar
RS 3	260.38x	2,80	3,05	3,30	3,55	3,75	3,95
	↓*	↓*	↓*	↓*	↓*	↓*	↓*
	260.68x	17,90	19,60	21,15	22,65	24,00	25,30
RS4	260.72x	22,40	24,50	26,45	28,28	30,00	31,62
	↓*	↓*	↓*	↓*	↓*	↓*	↓*
	260.92x	70,44	77,15	83,34	89,10	94,50	99,61

Explanations:

Spray angle: 30°, 45°, 60°, 90°

Spray pattern: Hollow cone

Turn down ratio 10 : 1

(max. flow : min. flow)

↓* Smallest and largest value is mentioned, to show the spectrum of flow rates.



Typical Spillback Nozzle Lances Arrangement and its Control System

A typical control system for a gas conditioning tower of a refuse incineration plant.

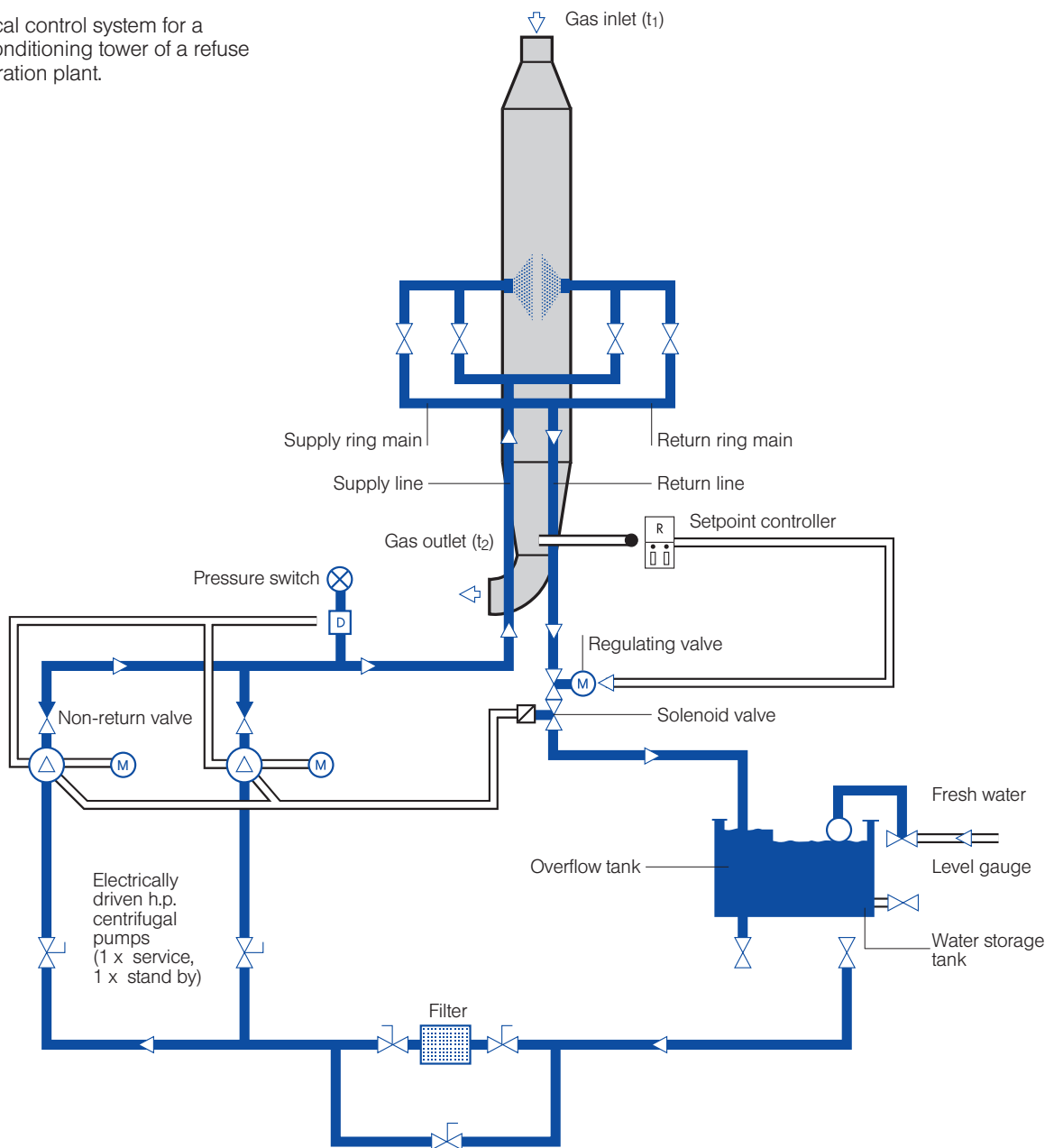

Choice of control system

Depending on the required actuating time and response

time the control valve can either be electric or electro-pneumatic.

Complete solutions with pump and regulation units and electronic controls

Lechler supplies complete, pre-assembled pump and regulator stations. The design of these stations is adapted to suit the function and mode of operation of the nozzle lances. The control valve, for example, is designed to match the special operating characteristics (required control range) of the installation. The choice of materials used for the components is determined by the medium to be sprayed.

Our range of engineering services includes:

- Gas cooling computations (evaporation distance and water quantity)
- Selection of nozzle (type, number and size)
- Design of pump, control valves, etc.

- Detail designs of water and barrier air pipe lines
- Designing flow sheets
- Designing drawings for nozzle lances, pump- and regulation units
- Documentation

The pump and regulation units can be equipped with the following components:

- Filters
- Contact pressure gauges
- Pressure gauges
- Pumps
- Control valves
- Flowmeters
- Non-return valves
- Overflow valves etc.

The measuring and monitoring instruments for the unit (flow measurements, pressure

monitoring) are established in cooperation with the customer. The correct choice of instrumentation ensures that the required operational reliability and safety are achieved. The components and interconnecting pipework are mounted on a stable rack. Pressure- and function-test and pre-commissioning at Lechler factory enables us to put the system into operation in a minimum of time after shipping the compact unit on site. In order to offer complete solutions, we can also supply the PLC required for temperature control. The switching cabinet can be integrated onto the valve rack.

Our complete engineering package includes:

- Designing the control system
- Flow charts
- Preparing the program for the PLC
- CAD circuit diagrams
- Documentation

Our complete system solution offers you a prefabricated installation tailored to your needs.

Large numbers of complete systems of this type have been built and installed for a range of applications throughout the world and have proved their worth in continuous operation.

We would be pleased to send you copies of our product- and country-specific reference lists.

Advantages:

- Complete solution from a single source including process guarantees
- No interfaces
- Systems adapted to suit operational requirements
- Minimal installation and commissioning times
- Compact units



Example of pump and regulation unit

Questionnaire for calculation of your gas conditioning requirements



Please reply to Lechler (Fax or e-mail see following page)

Dear customer,

to comment on your gas conditioning problem, we would require all data known to you and indispensable for computing. The more precise your indications are, the more reliable our calculations can be.

Company:..... Date:.....
 Address:..... Complement:.....
 Department:.....
 Phone/Fax:.....
 Projekt no.:.....

1. Gas data

■ Gas flow rate (under standard conditions,* humid)

Gas flow [Nm ³ /h*, humid]	t inlet [°C]		t outlet [°C]	
max.:	min.:	max.:		
nominal:	min.:	max.:	min.:	max.:
min.:	min.:	max.:		

If there are other design cases, please note separately

Gas composition [Vol. %]	H ₂ O	CO ₂	O ₂	N ₂			

- Other components of gas (HCl, HF, etc.)..... [mg/Nm³*, humid]
- Critical cooling limit temperature (dew point) Yes, at °C
- System pressure (in the reaction area) bar (g)

2. Conditions on site

- Are gas cooling tower dimensions fixed? Yes Ø..... dimensions
- No Favorite-Ø..... dimensions
- Available reaction distance m. Reaction distance to be determined.
- Direction of gas ↓ ↑ ⇒
- Dust content in gas mg/m³ i. N.
- Nozzle type: Single fluid Twinfluid Both types possible
- Complete evaporation required? Yes No
- Is water injection system always in operation? Yes No
- In case the operation is interrupted, running time %

3. Coolant data

- Coolant water Inlet temperature°C
(max. over pressure bar)..... Content of solids.....
- Medium (Twin fluid nozzles)
- Air Over pressure..... bar (g)
- Steam Over pressure..... bar (g)
Temperature°C

4. If available, please attach

- Process flow sheet
- Sketch/drawing of GCT

* T₀ = 273 K (0°C), P₀ = 1 bar





Lechler GmbH
 Precision Nozzles · Droplet Separators
 P.O. Box 13 23
 72544 Metzingen / Germany
 Phone: +49 (0) 71 23 962-0
 Fax: +49 (0) 71 23 962-301

E-Mail: info@lechler.de
 Internet: www.lechler.de



Lechler is your competent partner when it comes to exhaust-air cleaning and gas conditioning plants. Know-how from over 125 years of experience is available to all companies which manufacture or operate such plants.

Don't settle for less than the best when it comes to protecting the environment. Consult with the specialists from Lechler for the best application of nozzles, nozzle lances or droplet separators. A series of brochures is available to provide you with an initial insight. These brochures contain the comprehensive data and performance specifications which you will require in planning and maintaining your plant.

I am interested in Lechler's components for effective environmental protection. Please send me the marked information.

Company _____

Department _____

Name _____

Function _____

Street/P.O. Box _____

Post code/Town _____

Telephone _____

Telefax _____

E-mail _____

- Twin Fluid Nozzle Lances**
- VarioCool® Gas Conditioning Systems**
- Nozzles for Flue Gas Desulphurisation**

Belgium: Lechler S.A./N.V. · Avenue Mercatorlaan, 6 · 1300 Wavre · Phone: (10) 225022 · Fax: (10) 243901 · info@lechler.be
China: Lechler Intl. Trad. Co., Ltd. · Beijing Office · Rm.1812 CTS Plaza · No.2 Bei San Huan Dong Lu · Phone: (86) 1064661986, Fax: (86) 1064660196 · info@lechler.com.cn
Finland: Lechler Oy · Kalliotie 2 · 04360 Tuusula · Phone: (358) 98709844 · Fax: (358) 98709847 · info@lechler.fi
France: Lechler France, S.A. · Bât. CAP2 B51 · 66-72, Rue Marceau · 93558 Montreuil cedex · Phone: (1) 49882600 · Fax: (1) 49882609 · info@lechler.fr
Great Britain: Lechler Ltd. · 1 Fell Street, Newhall · Sheffield, S9 2TP · Phone: (0114) 2492020 · Fax: (0114) 2493600 · info@lechler.com
India: Lechler (India) Pvt. Ltd. · Plot B-2 · Main Road · Wagle Industrial Estate · Thane (W) · 400604 · Phone: (22) 25811196 · Fax: (22) 25821262 · lechler@lechlerindia.com
Sweden: Lechler AB · Box 158 · 68324 Hagfors · Phone: (46) 56325570 · Fax: (46) 56325571 · info@lechler.se
Spain: Lechler S.A. · Avda. Pirineos 7 · Oficina B7, Edificio Inbisa I · 28700 San Sebastián de los Reyes, Madrid · Phone: (34) 916586346 · Fax: (34) 916586347 · info@lechler.es
USA: Lechler Inc. · 445 Kautz Road · St. Charles, IL · 60174 · Phone: (630) 377-6611 · Fax: (630) 377-6657 · GeneralMgr@lechlerUSA.com