

Product Information

Pressure Transmitter EPS2



- Measuring cell made of stainless steel, hermetically welded
- Analog signal 4..20 mA (two-wire)
- Very rapid reaction time thanks to analog signal path with mixed signal ASIC
- Ranges from 0.6..2000 bar relative pressure
- Robust full metal housing
- Class: 0.5 % standard
- Working temperature -40 °C to +100 °C
- Poly-Si on SiO₂ (thin film resistors)
- M12x1 plug system (or others on request)

Characteristics

The pressure transducer measures pressures in liquids and gases. It has the following applications:

- Hydraulics
- Testing technology
- Pneumatics
- Industrial robots
- Mobile systems
- Process control
- Air-conditioning + heating
- Water technology
- Vehicle technology

The stainless steel membrane is fitted with a polysilicon thin film cell, completely vacuum-tight, extremely burst resistant, and it can be used in all applications which are compatible with stainless steel. The analog measuring path, which is conditioned by means of an ASIC, permits the most rapid response times, with the need for only a few components. The sensors are calibrated digitally, and the components have very good long term stability and a small total error.

Technical data

Sensor	thin film pressure measurement bridge on stainless steel membrane			
Process connection	male thread G 1/4 A			
Pressure type	relative pressure			
Metering ranges in bar	Range	Permitted overload pressure	Burst pressure	
● = preferred types	0.. 0.6	1.2	2.4	
	0.. 1.0	2.0	3.0	●
	0.. 2.0	4.0	6.0	●
	0.. 2.5	5.0	7.5	
	0.. 4.0	8.0	12.0	
	0.. 6.0	12.0	18.0	●
	0.. 10.0	20.0	30.0	●
	0.. 16.0	32.0	48.0	
	0.. 25.0	50.0	75.0	●
	0.. 40.0	80.0	120.0	●
	0.. 60.0	120.0	180.0	
	0.. 100.0	200.0	300.0	●
	0.. 160.0	320.0	480.0	
	0.. 250.0	500.0	750.0	●
	0.. 400.0	600.0	800.0	●
	0.. 600.0	900.0	1200.0	●
	0..1000.0	1200.0	1500.0	●
	0..1600.0	1920.0	2400.0	
	0..2000.0	2400.0	3000.0	
Measurement accuracy	accuracy class 0.5			
	total error (Non-linearity + hysteresis + temperature effect + repeatability):			
	-40..+20 °C	±3 % typically ±2 %		
	-20..+85 °C	±1 % typically ±0.7 %		
	85..100 °C	±2.5 % typically ±1.5 %		
Response time	(10..90 %) < 1 ms			
Pressure resistance	corresponds to metering range			
Media temperature	-40..+125 °C			
Ambient temperature	-40..+105 °C			
Storage temperature	-40..+125 °C			
Media	fluids and gases			
Materials medium-contact	1.4571			
Materials, non-medium-contact	Housing	stainless steel		
	Seal	FKM		
Supply voltage	12..32 V DC			
Analog output	4..20 mA two-wire			
Load	max. (battery voltage -12 V) / 20 mA			
Electrical connection	for round plug connector M12x1, 4-pole			
Reversal polarity protected	yes			
Ingress protection	IP 65 / 67			
Weight	approx. 0.2 kg			
Conformity	CE			

... professional Instruments "MADE IN GERMANY"

Product Information

EMC	interference radiation DIN EN 55011: < 30 dB µV/m Interference immunity DIN EN 61000-4-3: 25 V/m
Shock test	1 m onto steel plate (as per IEC68-2-32) Vibration 20 g (as per IEC 68-2-6 and 68-2-36)

Wiring



Before the electrical installation, it must be ensured that the supply voltage corresponds with the data sheet.

Dimensions

EPS2-....S

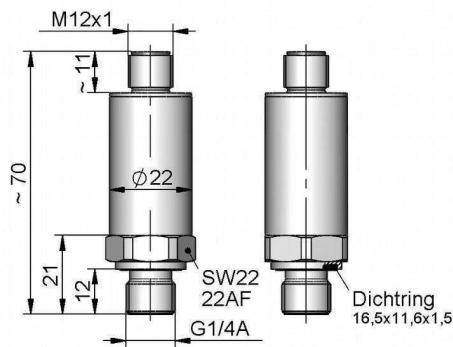

EPS2-....B

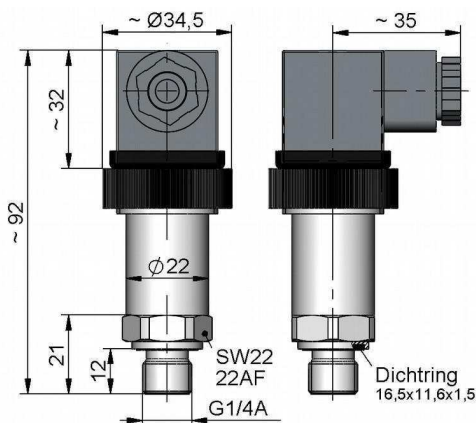

Handling and operation

Installation

The pressure transducers are screwed into a nozzle or a T-piece in the pipework. The seal is made by means of the integrated ED sealing ring. The installation of the pressure transducer should result in no significant reduction of the cross-section of the pipework. When tightening the pressure transducer, use only the hexagonal spanner (SW22) specifically provided. Avoid installation locations with high pressure surges (see permitted overload pressure).

Ordering code

EPS2 - 1. 2. 3. 4. 5.

Example: EPS2 - R K 008

○ = Option

1. Metering range	
00006	○ 0.. 0.6 bar
00010	○ 0.. 1.0 bar
00020	○ 0.. 2.0 bar
00025	○ 0.. 2.5 bar
00040	○ 0.. 4.0 bar
00060	○ 0.. 6.0 bar
00100	○ 0.. 10.0 bar
00160	○ 0.. 16.0 bar
00250	○ 0.. 25.0 bar
00400	○ 0.. 40.0 bar
00600	○ 0.. 60.0 bar
01000	○ 0.. 100.0 bar
01600	○ 0.. 160.0 bar
02500	○ 0.. 250.0 bar
04000	○ 0.. 400.0 bar
06000	○ 0.. 600.0 bar
10000	○ 0..1000.0 bar
16000	○ 0..1600.0 bar
20000	○ 0..2000.0 bar
2. Pressure type	
R	relative pressure
3. Connection material	
K	stainless steel 1.4571
4. Connection size	
008	male thread G 1/4 A
5. Electronic connection	
S	for round plug connector M12x1, 4-pole
B	○ plug DIN 43650-A / ISO 4400

Options

- Special measuring ranges

Accessories

- Cable/round plug connector (KB...) see additional information "Accessories"

... professional Instruments "MADE IN GERMANY"