

IDROBASE[®]

PASSION FOR WATER



Idrobases Group corporate video



Idrotech by Idrobases Group
Misting Systems at Expo 2015



Misting Book

EN

Residential & Commercial misting



Choose your own customised nebulisation solution to meet your environment refreshing needs

Kit Linea

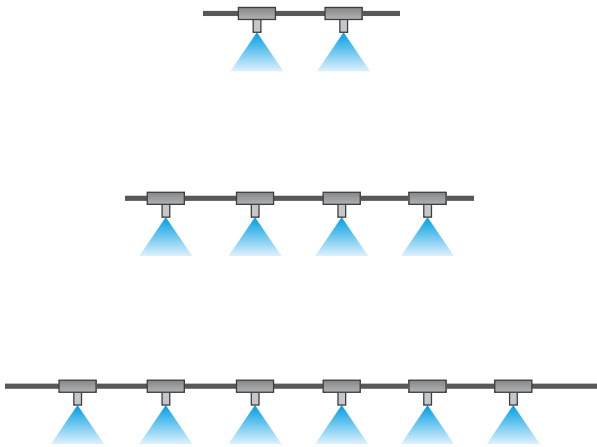

Kit Vento

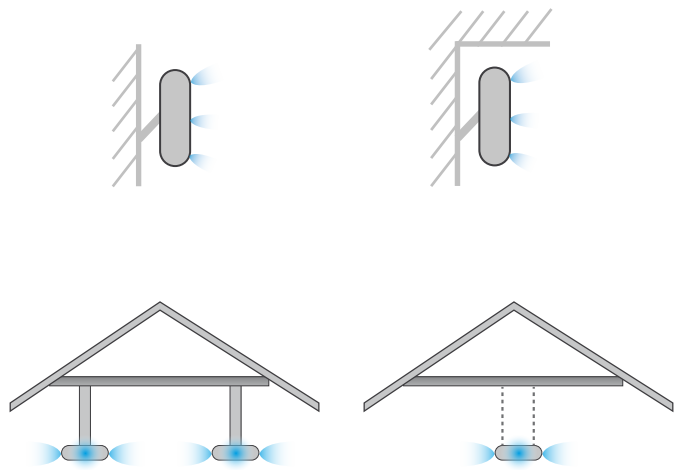

Optimal solution for:

- *outdoor gazebos*
- *verandas*
- *outdoor walkways*
- *refreshing systems for outdoor umbrellas*
- *beach volleyball, futsal/tennis pitches/courts*

Optimal solution for:

- *industrial workshops*
- *covered outdoor areas of restaurants, bars and bakeries*
- *parks and gardens*
- *gyms*
- *fishmongers' & greengrocers'*

Kit Linea



Kit Vento



Linea kit

Choose your line type

Pumping modules

Fog App



Fog Eco Pro



Fog Extra



Code	Description	Coverage in square metres	Pumping modules						Price	
			ZX.FA1.0	ZX.FA1.5	ZX.5095-RC	ZX.5090-RC	ZX.FL-05	ZX.FL-1		ZX.FL-2
ZX.KL10	Linea kit 10 nozzles	6,75m			●			●		€330,00*
ZX.KL20	Linea kit 20 nozzles	14,25m	●			●		●		€630,00*
ZX.KL30	Linea kit 30 nozzles	21,75m		●					●	€930,00*
ZX.KL40	Linea kit 40 nozzles	29,25m							●	€1250,00*



Example Linea Kit composition

Linea kit	Description	Linea Kit codes			
		ZX.KL10	ZX.KL20	ZX.KL30	ZX.KL40
	H.p. polyamide pipe ø6.35mm , black, 5m rolls	1pcs	1pcs	1pcs	2pcs
	AISI 304 stainless steel pipe ø6.35mm - 750mm	9pcs	19pcs	29pcs	39pcs
	Straight nozzle holder Slip-Lock quick coupling , in nickel-plated brass, ø6.35mm	9pcs	19pcs	29pcs	39pcs
	End of line nozzle holder Slip-Lock quick coupling , in nickel-plated brass, ø6.35mm	1pcs	1pcs	1pcs	1pcs
	Cleanable fog nozzle in nickel-plated brass , complete with anti-drip valve and 50micron mesh filter, 10/24UNC/2A thread, flow factor 015	10pcs	20pcs	30pcs	40pcs
	Rubberised SS pipe clamp , for polyamide pipe and AISI 304 SS pipe fixing ø6.35mm	16pcs	26pcs	36pcs	51pcs
	Tube cutter for polyamide pipe ø2-12mm	1pcs	1pcs	1pcs	1pcs
Recommended accessory		Price			
ZX.KPI	Emergency kit: 2 cleanable fog nozzles in nickel-plated brass, 1 pipe "tee" junction Slip-Lock quick coupling, 1 Slip-Lock line end cap, 2 rubberised stainless steel pipe caps, 1 cap with 10/24UNC/2A thread	€36,10*			

Kit Vento

Choose your fan type

Pumping modules



Fog Eco Pro



Fog Extra



	Code	Description	Coverage in square metres	Number of fans	Fog App		Fog Eco Pro		Fog Extra			Price	
					ZX.FA1.0	ZX.FA1.5	ZX.5095-RC	ZX.5090-RC	ZX.FL-05	ZX.FL-1	ZX.FL-2		
	Fan 20"	ZX.KV2-20	Kit 2 Mist Fan 20"	80m ²	2	●		●		●		€850,00*	
		ZX.KV4-20	Kit 4 Mist Fan 20"	160m ²	4	●			●		●	€1.695,00*	
		ZX.KV6-20	Kit 6 Mist Fan 20"	240m ²	6		●					●	€2.540,00*
		ZX.KV8-20	Kit 8 Mist Fan 20"	320m ²	8							●	€3.385,00*
	Fan 18"	ZX.KV2-18	Kit 2 Mist Fan 18"	100m ²	2	●		●		●		€1.300,00*	
		ZX.KV4-18	Kit 4 Mist Fan 18"	200m ²	4	●			●		●	€2.600,00*	
		ZX.KV6-18	Kit 6 Mist Fan 18"	300m ²	6		●					●	€3.890,00*
		ZX.KV8-18	Kit 8 Mist Fan 18"	400m ²	8							●	€5.190,00*
	Fan 360°	ZX.KV2-360	Kit 2 Mist Fan 360	60m ²	2	●		●		●		€1.230,00*	
		ZX.KV4-360	Kit 4 Mist Fan 360	120m ²	4	●			●		●	€2.455,00*	
		ZX.KV6-360	Kit 6 Mist Fan 360	180m ²	6		●					●	€3.680,00*
		ZX.KV8-360	Kit 8 Mist Fan 360	480m ²	8							●	€4.905,00*
	Fan Panorama	ZX.KV2-P	Kit 2 Fan 360 Panorama	100m ²	2	●			●		●	€1.965,00*	
		ZX.KV4-P	Kit 4 Fan 360 Panorama	200m ²	4		●					●	€3.925,00*

KIT MIST FAN 20"



51,5cm



For covered areas



Example Vento Kit Composition

Vento kit	Description	ZX-KV2-20	ZX-KV4-20	ZX-KV6-20	ZX-KV8-20
	Mist Fan 20" - 51.5cm 3 speeds, 90° swinging, complete with a wall mounting bracket, white colour, power cable length 2.2m. Air flow rate 2940m ³ /h, 74W, 230V-50Hz. Coverage 40m ²	2pcs	4pcs	6pcs	8pcs
	AISI 304 stainless steel nozzle holder ring , 6 holes, 10/24UNC/2A thread for Mist Fan 18", Slip-Lock inlet ø6.35mm	2pcs	4pcs	6pcs	8pcs
	Fog nozzle in nickel-plated brass , complete with anti-drip valve and cleanable 50micron mesh filter, 10/24UNC/2A thread, flow factor 015	12pcs	24pcs	36pcs	48pcs
	Nickel-plated brass cap 10/24UNC/2A thread	4pcs	8pcs	12pcs	16pcs
	"Tee" pipe junction Slip-Lock quick coupling , in nickel-plated brass, ø6.35mm	1pcs	3pcs	5pcs	7pcs
	H.p. polyamide pipe ø6.35mm , rolls of 25m, white	1pcs	2pcs	3pcs	4pcs
	Tube cutter for polyamide pipe ø2-12mm	1pcs	1pcs	1pcs	1pcs
	Rubberised stainless steel pipe clamp , for polyamide pipe fixing ø6.35mm	20pcs	40pcs	60pcs	80pcs
Recommended accessory					Price
ZX.KPI	Emergency kit: 2 cleanable fog nozzles in nickel-plated brass, 1 pipe "tee" junction Slip-Lock quick coupling, 1 Slip-Lock line end cap, 2 rubberised stainless steel pipe caps, 1 cap with 10/24UNC/2A thread				€36,10*

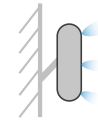

KIT MIST FAN 18"



Example Vento Kit Composition

Vento kit	Description	ZX-KV2-18	ZX-KV4-18	ZX-KV6-18	ZX-KV8-18
	Mist Fan 18" - 46cm axial, 3 speeds, pre-set for mounting on wall, swinging 90°, colour white, length of power cable 2.2m. Air flow rate 9000m ³ /h, 125W, 230V-50Hz. Coverage 50m ²	2pcs	4pcs	6pcs	8pcs
	Wall mounting bracket for Mist Fan 18"	2pcs	4pcs	6pcs	8pcs
	AISI 304 stainless steel nozzle holder ring , 6 holes, 10/24UNC/2A thread for Mist Fan 18", Slip-Lock inlet ø6.35mm	2pcs	4pcs	6pcs	8pcs
	Fog nozzle in nickel-plated brass , complete with anti-drip valve and cleanable 50micron mesh filter, 10/24UNC/2A thread, flow factor 015	12pcs	24pcs	36pcs	48pcs
	Nickel-plated brass cap 10/24UNC/2A thread	4pcs	8pcs	12pcs	16pcs
	"Tee" pipe junction Slip-Lock quick coupling , in nickel-plated brass, ø6.35mm	1pcs	3pcs	5pcs	7pcs
	H.p. polyamide pipe ø6.35mm , rolls of 25m, white	1pcs	2pcs	3pcs	4pcs
	Tube cutter for polyamide pipe ø2-12mm	1pcs	1pcs	1pcs	1pcs
	Rubberised stainless steel pipe clamp , for polyamide pipe fixing ø6.35mm	20pcs	40pcs	60pcs	80pcs

Recommended accessory				Price
ZX.KPI	Emergency kit: 2 cleanable fog nozzles in nickel-plated brass, 1 pipe "tee" junction Slip-Lock quick coupling, 1 Slip-Lock line end cap, 2 rubberised stainless steel pipe caps, 1 cap with 10/24UNC/2A thread			€36,10*

KIT MIST FAN 360°

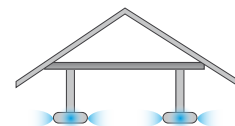





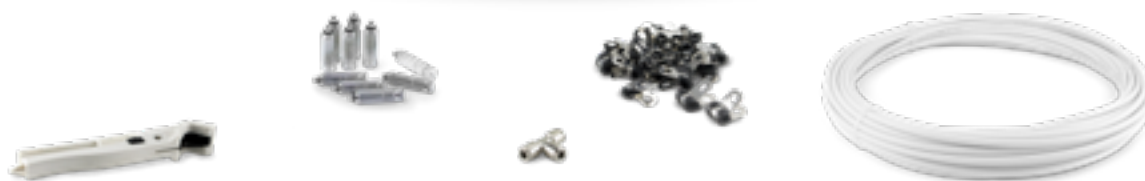
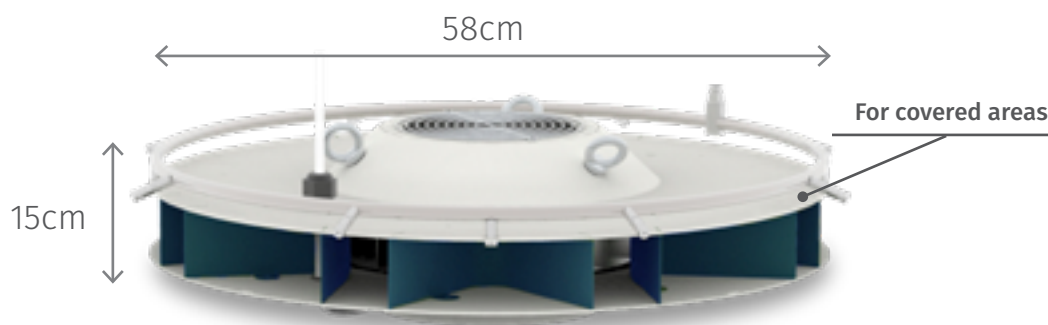
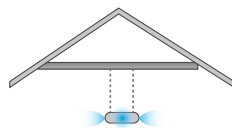

Example Vento Kit Composition

Vento kit	Description	ZX-KV2-360	ZX-KV4-360	ZX-KV6-360	ZX-KV8-360
	Mist Fan 360° - single speed, complete with ceiling mounting bracket, holder ring for 6 nozzles, colour white. Air flow rate 4,020m ³ /h, 97W, 230V-50Hz. Coverage 30m ²	2pcs	4pcs	6pcs	8pcs
	Fog nozzle in nickel-plated brass , complete with anti-drip valve and cleanable 50micron mesh filter, 10/24UNC/2A thread, flow factor 015	12pcs	24pcs	36pcs	48pcs
	"Tee" pipe junction Slip-Lock quick coupling , in nickel-plated brass, ø6.35mm	1pcs	3pcs	5pcs	7pcs
	H.p. polyamide pipe ø6.35mm , rolls of 25m, white	1pcs	2pcs	3pcs	4pcs
	Tube cutter for polyamide pipe ø2-12mm	1pcs	1pcs	1pcs	1pcs
	Rubberised stainless steel pipe clamp , for polyamide pipe fixing ø6.35mm	20pcs	40pcs	60pcs	80pcs
Recommended accessory					Price
ZX.KPI	Emergency kit: 2 cleanable fog nozzles in nickel-plated brass, 1 pipe "tee" junction Slip-Lock quick coupling, 1 Slip-Lock line end cap, 2 rubberised stainless steel pipe caps, 1 cap with 10/24UNC/2A thread				€36,10*

KIT FAN 360° PANORAMA



Example Vento Kit Composition

Vento kit	Description	ZX.KV2-P	ZX.KV4-P
	Fan 360° Panorama. Single speed, pre-set for ceiling mounting, complete with holder ring for 8 nozzles, colour white, air flow rate 600m ³ /h, 100W, 230V-50Hz. Coverage 50m ²	2pcs	4pcs
	Fog nozzle in nickel-plated brass, complete with anti-drip valve and cleanable 50micron mesh filter, 10/24UNC/2A thread, flow factor 015	16pcs	24pcs
	"Tee" pipe junction Slip-Lock quick coupling, in nickel-plated brass, ø6.35mm	1pcs	3pcs
	H.p. polyamide pipe ø6.35mm, rolls of 25m, white	1pcs	2pcs
	Tube cutter for polyamide pipe ø2-12mm	1pcs	1pcs
	Rubberised stainless steel pipe clamp, for polyamide pipe fixing ø6.35mm	20pcs	40pcs
Recommended accessory			Price
ZX.KPI	Emergency kit: 2 cleanable fog nozzles in nickel-plated brass, 1 pipe "tee" junction Slip-Lock quick coupling, 1 Slip-Lock line end cap, 2 rubberised stainless steel pipe caps, 1 cap with 10/24UNC/2A thread	€36,10*	



Smartphone controlled



Fog module 60bar
230V-50Hz



Fog App: the new solution for refreshing outdoor areas via smartphones



Water inlet filter as standard, with 80micron AISI 304 stainless steel mesh. Works in conjunction with IT.0581 water supply Kit

Simple and effective

Fog App is the smartest solution to **refresh** bars, restaurants, patios in small and medium-sized areas. The system can be connected to both ventilation and in-line cooling systems and can be **controlled** conveniently **from the application via a smartphone**.



Silent working



Considerably reduces the temperature



Keeps mosquitoes away



Simple mode to select:
- operation time:
- up to max 4 time slots
- work/pause time:
with min work time of 3s and min pause time of 15s



Advanced mode to select:
- operation time:
- time slots as required
- work/pause time: customised for each time slot with min work time of 3s and min pause time of 15s



Slip-Lock connectors for water inlet $\varnothing 9.6\text{mm}$ and water outlet $\varnothing 6.35\text{mm}$

Tech. features

Code	Model	*No. of nozzles 50Hz	Pressure	Fl. rate 50Hz	Power absorption	Wght	Price
ZX.FA1.0	FOG APP 1	20	60bar	1l/min	180W (230V-50Hz)	10kg	€1.150,00*
ZX.FA1.5	FOG APP 1,5	30	60bar	1,5l/min	180W (230V-50Hz)	10kg	€1.150,00*

* The max number of nozzles has been calculated by using a nozzle with flow rate factor 015 (0.047l/min) at 60bar

FOG APP is compatible with:

Linea kit ZX.KL20 and ZX.KL30

Kit Vento ZX.KV4-20, ZX.KV6-20, ZX.KV2-18, ZX.KV4-18, ZX.KV6-18, ZX.KV2-360, ZX.KV4-360, ZX.KV6-360, ZX.KV2-P and ZX.KV4-P

Recommended accessories

	IT.0581	Water supply kit complete with mesh filter, and Fog module 3m water connection pipe	€19,80*		ZX.0561	Pressure gauge kit in AISI 304 stainless steel, ø40mm, 1/4" M-F, 0-160bar	€20,10*
	IT.0582	Anti-limescale filter with polyphosphate salts for water supply kit	€5,80*				

Fog App control panel

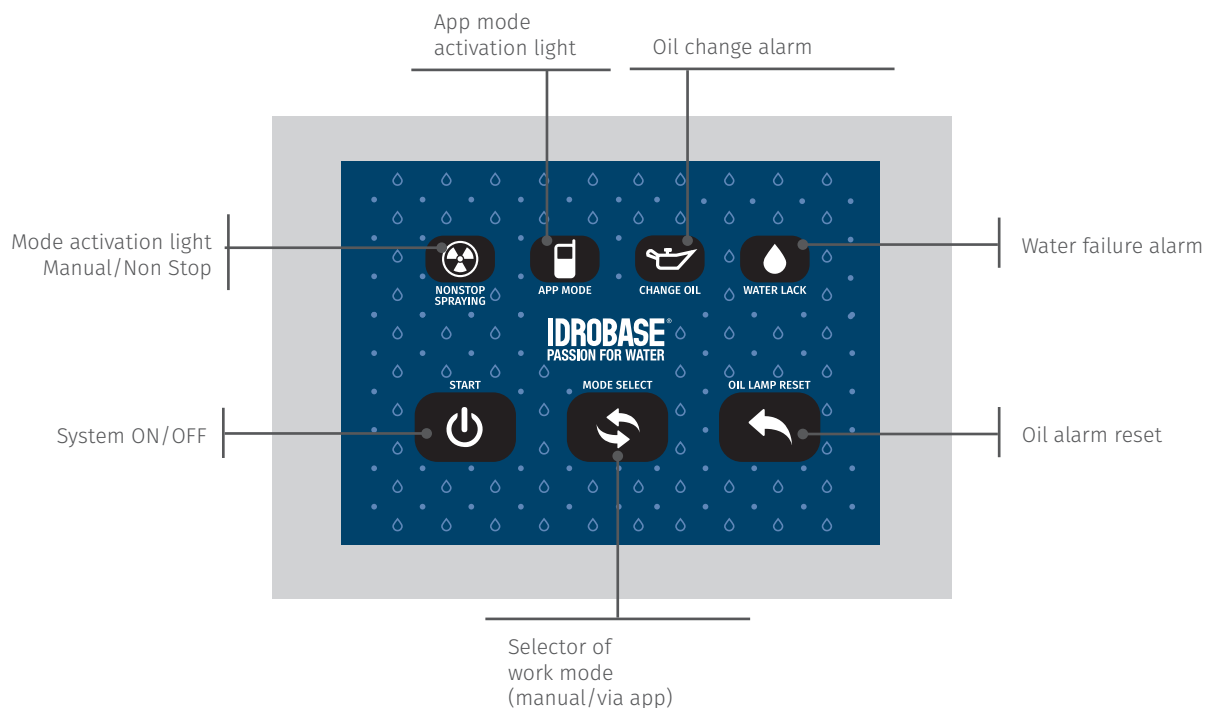

Technical features

- **Frame** made of galvanised painted plate
- **Electric pump** 3 pistons, axial, with brass head
- **Thermal protection** against current surge
- **Unloader valve**
- **LP pressure switch** due to lack of water
- **Solenoid valve** l.p. water inlet
- **Solenoid valve** h.p. for pressure discharge
- **Inlet, Slip-Lock** ø9.6mm
- **Outlet, Slip-Lock** ø6.35mm
- **Instrument panel with 3 touch buttons** for:
 - machine ON/OFF
 - Manual mode selection or Bluetooth activation for smartphone control
 - Alarms reset for maintenance
- **Possibility to manage 3 different modes via the app:**
 - *Nonstop*: the Fog module works in continuous mode
 - *Simple mode*: selection of days of the week, selection of max 4 time slots, work/pause time selection with min 3s work time and min 15s pause time
 - *Advanced mode*: selection of the days of the week, selection of max 20 time slots, selection of work/pause times customised for each time slot with min 3s work time and min 15s pause time
- **Dimensions WxLxH:** 415 x 250 x 215mm

FOG Eco Pro

NEW!



Controlled by
radio control



Fog module 60bar
230V-50Hz



Water inlet filter as standard, with 80micron AISI 304 stainless steel mesh. Works in conjunction with IT.0581 water supply Kit



Considerably reduces the temperature



No wet



Keeps mosquitoes away



Silent working

Compact and versatile

The most **compact** and **versatile** solution for cooling, creating fog effects and humidifying small and medium sized areas. Wide variety of **accessories** and types of line **matchable as required** for use in a wide range of applications.



Slip-Lock connectors for water inlet $\varnothing 9.6\text{mm}$ and water outlet $\varnothing 6.35\text{mm}$



Timing of pause/work pre-settings:

- T1 15" ON - 10" OFF
- T2 20" ON - 15" OFF
- T3 20" ON - 30" OFF



Radio control range 15m with 4 channels:

- ON/OFF pump
- ON/OFF lights
- ON/OFF fans
- ON/OFF pump and fans

Tech. features

Code	Model	*Nozzles n°	Pressure	Fl. rate	Power absorption	Wght	Price
ZX.5095-RC	FOG ECO PRO 05	10	60bar	0,5l/min	125W (1x230V-50Hz)	15kg	€1.350,00*
ZX.5090-RC	FOG ECO PRO 1	20	60bar	1l/min	200W (1x230V-50Hz)	15kg	€1.350,00*

* The max number of nozzles has been calculated by using a nozzle with flow rate factor 15 (0.047l/min) at 60bar

FOG ECO PRO is compatible with:	
Linea kit	ZX.KL10 and ZX.KL20
Kit Vento	ZX.KV2-20, ZX.KV4-20, ZX.KV2-18, ZX.KV4-18, ZX.KV2-360, ZX.KV4-360, and ZX.KV2-P

Recommended accessories

	IT.0581	Water supply kit complete with mesh filter, and Fog module 3m water connection pipe	€19,80*		IT.0269-20	Temperature probe for remote control IT.0104, 20m cable	€78,80*
	IT.0582	Anti-limescale filter with polyphosphate salts for water supply kit	€5,80*		IT.0105	Humidistat remote control , ideal for controlling and maintaining the desired humidity level in an environment	€438,00*
	ZX.0561	Pressure gauge kit in AISI 304 stainless steel, ø63mm, 1/4" M, 0-160bar	€20,10*		IT.0137-20	Humidity probe for remote control IT.0105, with 20m cable	€390,00*
	IT.0104	Thermostat remote control , complete with temperaturesensing probe	€356,00*				

Fog Eco Pro controls

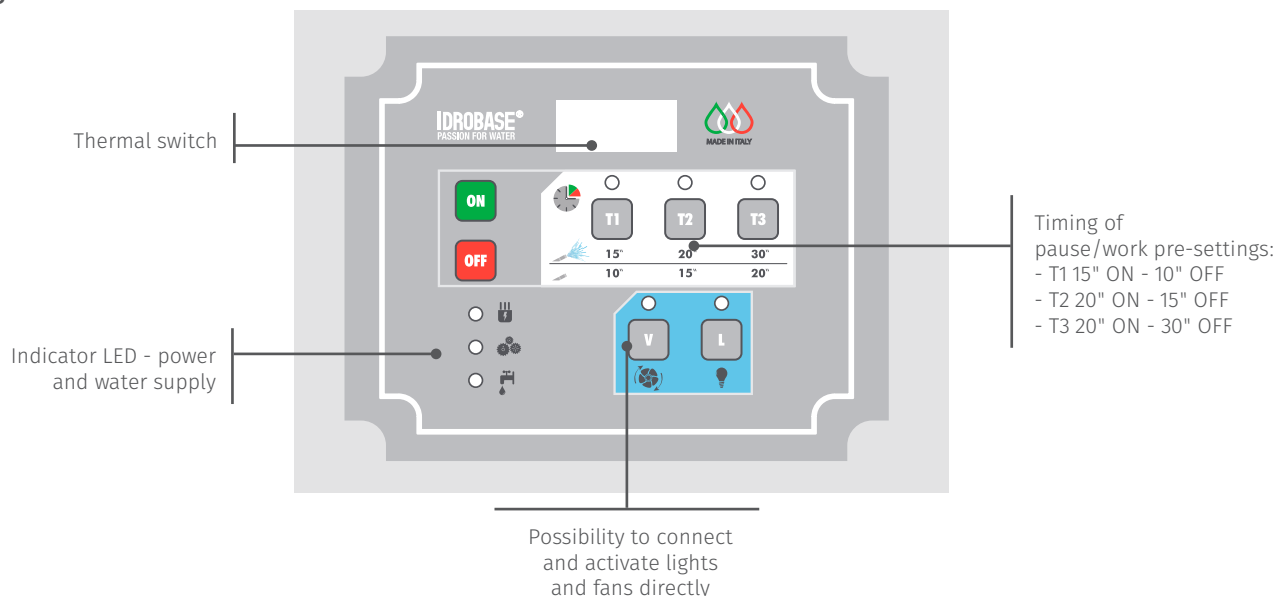

Technical features

- **Frame** made of painted steel
- **Axial motor pump with two ceramic pistons** 0.5 and 1l/min complete with by-pass valve
- **Electric control panel - with three time pre-settings**(with the option to directly operate the fans)
- **Solenoid valve- low pressure water inlet**
- **Solenoid valve** high pressure for pressure discharge
- **Pressure switch- low pressure no water supply**
- **Control panel** complete with: ON/OFF thermal cutout switch, continuous work mode or with 3 pause/work settings. Preset for connecting external devices (level sensor, fans, UV lamp, lights)
- **Four-channel radio remote control:** pump on/off, lights on/off, combined pump and fans on/off
- **Slip-lock inlet** ø9.6mm
- **Outlet, Slip-Lock** ø6.35mm
- **Dimensions LxDxH:** 450 x 300 x 280mm

FOG *Extra*



Probes



Control panel



MADE IN ITALY



Fog module 60bar
230V-50Hz



Fog Extra to cool, humidify, suppress dust and odours and many more



Water inlet filter as standard, with 80micron AISI 304 stainless steel mesh. Works in conjunction with IT.0581 water supply Kit

Compact and versatile

The most **compact** and **versatile** solution to cool, create fog effects, humidify, suppress dust and odours in small and medium sized areas. Wide variety of **accessories** and types of line **matchable as required** for use in a wide range of applications.

The new control panel allows for quick and accurate setting of the work times and management of the connected optional probes.

SECURITY SYSTEM ANTI-FLOODING:

in the event of pipe breaks on the fog nozzle lines, the system automatically shuts down to prevent flooding in the areas where the lines are installed



Slip-Lock connectors for water inlet $\varnothing 9.6\text{mm}$ and water outlet $\varnothing 6.35\text{mm}$. Outside air intake for motor pump unit cooling



Pump with brass head (for the ZX.FL-2 version with 2l/min capacity)



Electrical connections for humidity ZX.SU20 and temperature ZX.ST20 probes

Axial pump with 2 pistons

Code	Model	*No. of nozzles	Max pressure	Fl. rate	Power	Wght	Price
ZX.FL-05	Fog Extra 05/60	10	60bar	0,5l/min	125W (1x230V 50Hz)	15kg	€1.450,00*
ZX.FL-1	Fog Extra 1/60	20	60bar	1l/min	200W (1x230V 50Hz)	15kg	€1.550,00*

Axial pump with 2 ceramic pistons, head in nickel-plated brass, integrated bypass valve, electric motor 1350rpm,

Axial pump with 3 pistons

Code	Model	*No. of nozzles	Max pressure	Fl. rate	Power	Wght	Price
ZX.FL-2	Fog Extra 2/60	40	60bar	2l/min	720W (1x230V 50Hz)	30kg	€1.785,00*

Axial motor pump with three ceramic-coated steel pistons, brass head, integrated by-pass valve, electric motor 1450rpm.

* The max number of nozzles has been calculated by using a nozzle with flow rate factor 15 (0.047l/min) at 60bar

FOG EXTRA is compatible with:

Linea kit	ZX.KL10, ZX.KL20, ZX.KL30 and ZX.KL40
Kit Vento	ZX.KV2-20, ZX.KV4-20, ZX.KV2-18, ZX.KV4-18, ZX.KV2-360, ZX.KV4-360, and ZX.KV2-P

Recommended accessories

	IT.0581	Water supply kit complete with mesh filter, and Fog module 3m water connection pipe	€19,80*		ZX.ST20	Humidity probe (for standard thermostat), with 20m cable	€83,40*
	IT.0582	Anti-limescale filter with polyphosphate salts for water supply kit	€5,80*		ZX.SU20	Humidity probe 4:20 mA (for standard humidstat), with 20m cable	€385,00*

Fog Extra Controls

- Humidstat **standard**
- Thermostat **standard**
- Display interface
- Cyclical ON/OFF timer
- Weekly time slot programmer
- Hour counter and maintenance schedule
- Pre-setting for connection of 230V ventilation systems
- Pre-setting for remote connection

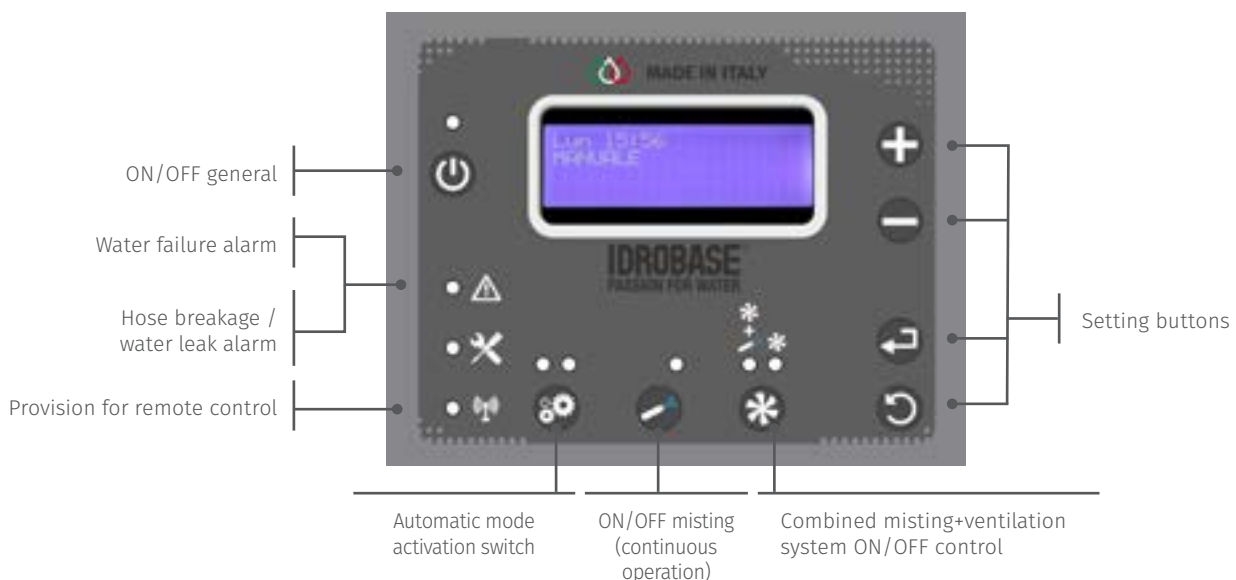

Technical features

- **Frame** made of painted steel
- **Unloader valve**
- **LP solenoid valve** 230V-50Hz, inlet water
- **H.p. solenoid valve** 230V-50Hz, to discharge line pressure
- **Electrical panel** complete with: ON/OFF thermal cutout, electronic board for management of anti-drip and timer system
- **Slip-lock inlet** $\varnothing 9.6\text{mm}$
- **Outlet, Slip-Lock** $\varnothing 6.35\text{mm}$
- **H. p. switch** for no water supply and pipe breaks
- **Dimensions WxLxH:** 600 x 300 x 300mm

Palma Rinfrescante

Refreshing accessory with 304 stainless steel structure complete with 6 pre-drilled pipes, connection fittings and 24 fog nozzles with 0.15mm holes with anti-drip system.

With buried connections and ground fixing of the structure.

Straightforward, quick installation, no special tools required.

The pipe junction connectors are made of AISI 304 SS and are equipped with compression fitting and a Slip-Lock connector to accommodate a high pressure polyamide pipe (max 60bar) $\varnothing 9.6 \times 5 \text{ mm}$. They must be connected to a nebulisation system

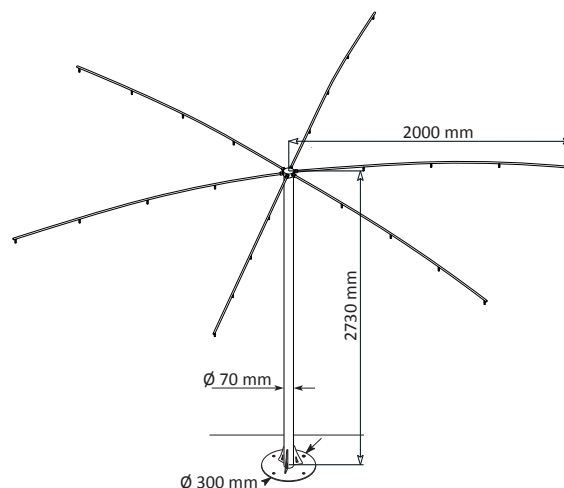

Model	Operating pressure	Water requirement at 60bars	Dimensions L x W x H	Price	
ZX.6000	Palma Rinfrescante	60bar	2l/ min	2000 x 2000 x 2730mm	€1.440,00*

Parasole Rinfrescante

Refreshing accessory with 304 stainless steel structure complete with 3 pre-drilled pipes, wall fixing bracket, connection fittings and 12 fog nozzles with 0.15mm holes with anti-drip system.

Straightforward, quick installation, no special tools required.

The pipe junction connectors are made of AISI 304 SS and are equipped with compression fitting and a Slip-Lock connector to contain a high pressure polyamide pipe (max 60bar) $\varnothing 9.6 \times 5 \text{ mm}$. They must be connected to a nebulisation system

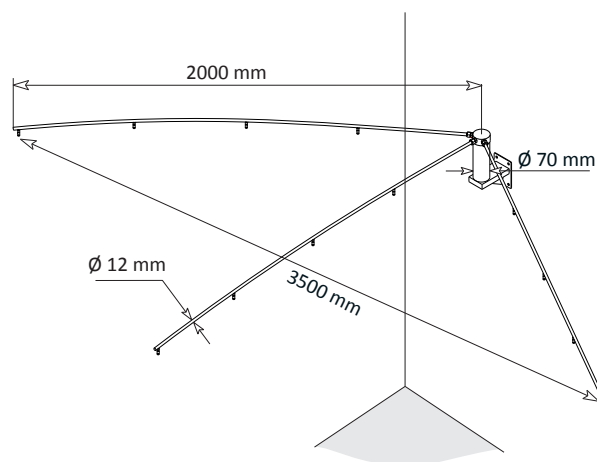

Model	Operating pressure	Water requirement at 60bars	Dimensions L x W	Price	
ZX.6001	Parasole Rinfrescante	60bar	0,5l/ min	2000 x 2000 mm	€680,00*

Stelo Rinfrescante

Refreshing accessory with pre-drilled 304 stainless steel structure, complete with 10 fog nozzles with 0.15mm holes with anti-drip system. With buried connections and ground fixing of the structure. Straightforward, quick installation, no special tools required. The pipe junction connectors are made of AISI 304 SS and are equipped with compression fitting and a Slip-Lock connector to accommodate a high pressure polyamide pipe (max 60bar) $\varnothing 9.6 \times 5 \text{mm}$. They must be connected to a nebulisation system

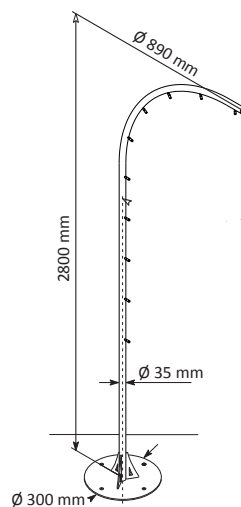

Model	Operating pressure	Water requirement at 60bars	Dimensions L x W x H	Price	
ZX.6002	Stelo Rinfrescante	60bar	0,5l/min	890 x 890 x 2800mm	€760,00*

Choose your refreshing accessory

Pumping modules

Fog App



Fog Eco Pro



Fog Extra



Code	Description	*No. of nozzles	ZX-FA1.0	ZX-FA1.5	ZX-5095-RC	ZX-5090-RC	ZX-FL-05	ZX-FL-1	ZX-FL-2	Price
ZX.6000	Palma Rinfrescante	24							●	€1.440,00*
ZX.6001	Parasole Rinfrescante	18	●			●		●		€680,00*
ZX.6002	Stelo Rinfrescante	10	●		●		●			€760,00*

IDROBASE®
PASSION FOR WATER

Super
MARKET



Humidification kit for
Supermarket



NEW!

HUMIDIFICATION
IN SUPERMARKETS



Fruit, vegetables, fish and flowers always perfectly fresh

The Italian-made **humidification systems** by Idrotech, Idrobases Group, are specially designed to **preserve the freshness** of food produce such as fruit, vegetables, fish and flowers. These systems **prevent the dehydration** of fresh products by means of filtered and sterilised water sprayed on the counters through nozzles arranged along a

steel or Grilamid line. **Humidification prolongs the shelf-life of fruit, vegetables, fish and flowers by rehydrating them with an action that reduces their weight loss and also preserves their fresh appearance. Our misting systems help boost sales and reduce product weight loss by up to 50%.**

Products stay fresh much longer: to offer your customers products as fresh as just harvested from the field!

Our solution for limiting the financial loss caused by dehydration:

vegetables will lose between 15 and 58% of their weight, while **fish will lose 12%**. **Humidification** offers considerable advantages to retailers: **it reduces the weight loss of these products up to 90% and prolongs their freshness**

Refrigerated counters, non-refrigerated display cases, and storehouses are all low-humidity environments (50-60%). This causes the rapid deterioration of most fruit and vegetables,

which lose weight, change colour and take on an uninviting appearance.

On the contrary, correctly humidified products will look **just harvested**, with **moist, firm and fresh surfaces**. To maintain the right humidity level as long as possible during display and storage.

Our humidification system is fully automatic: it features great versatility and extremely low operating costs.



To understand how much you can save, let's examine the produce department of a supermarket:

- Daily sales= **€ 500**
- Without Idrobase Group **humidification** : losses due to weight loss or deterioration **8%= € 40**
- With Idrobase Group **humidification** : losses due to weight loss or deterioration **4%= €20**
- Daily savings= **€ 20**
- **Annual savings:** € 20 x 300 working days = **€ 6000**



We keep your supermarket products in great shape

	Typical daily weight loss	Daily weight loss with Humi Fog / Humi Extra	Reduction in weight loss	Change in appearance
Artichoke	4.05%	0.58%	85.68%	★★★★
Avocados	0.38%	0.08%	79.62%	★
Broccoli	7.55%	0.75%	90.07%	★★
Brussels sprouts	3.47%	1.54%	55.62%	★★★★
Cabbage	1.39%	0.28%	79.86%	★★★★
carrots	4.65%	1.61%	65.38%	★★
Cauliflower	2.04%	0.41%	79.90%	★★★★
Celery	3.08%	1.29%	58.12%	★★
Grpfruit	0.64%	0.21%	67.19%	★★★★
Grp	1.46%	0.73%	50.00%	★★★★
Lemons	1.17%	0.36%	69.23%	★
Lettuce	7.05%	0.92%	86.95%	★★★★★
Mshroom	12.06%	5.90%	51.04%	★★★★★
Lg mushroom	12.09%	4.58%	62.10%	★★★★★
Oranges	0.45%	0.22%	51.11%	★
Peaches	3.38%	2.23%	34.09%	★★★★
Plums	0.83%	0.41%	49.79%	★★★★
Radishes	5.88%	2.94%	50.00%	★★★★★
Strberry	2.43%	1.11%	54.23%	★★
Tomatoes	0.23%	0.07%	69.30%	★

Carefree humidification

If you decide to use **our humidification system** in your store, **Idrotech** will **design** the most functional system, ensure perfect **installation** and carry out **maintenance**, to guarantee all the **benefits of humidification**, a **successful outcome** and **maximum user-friendliness**.





The benefits are clear

The following graphs compare 5°C refrigerated environments that are not humidified with others that are humidified. (Considering products kept at an **ideal degree of humidification**). Humi Fog and Humi Extra allow for **perfect rehydration**, therefore, the **benefit** derived from using this system will be **substantially greater** than that indicated by the graphs.





Why you should choose our humidification:

- 

Greater economic savings, **50% savings** compared to the average competing systems on the market
- 

Minimum footprint: **50x50x15cm**
- 

80% less maintenance compared to other systems
- 

Perfect Electronic anti-drip system, to prevent unpleasant dripping
- 

Installation takes about **1 hour**, instead of the 3 hours of other systems
- 

Built-in **sterilisation system** to guarantee sanitised water
- 

Low energy consumption, **125W** compared to other systems which require 800W
- 

Humidification keeps away annoying and anti-hygienic flying insects

Humidification kit in supermarkets



The solution to ensure humidification in supermarkets

The humidification kit in supermarkets includes several solutions:

Humidification Kit for supermarkets



Medium pressure Humi Fog



Humi Fog: medium pressure humidification system for **small areas** in supermarkets

Fog Extra to cool, humidify, suppress dust and odours and many more

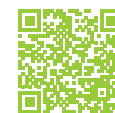

High pressure Humi Extra



Humi Extra: high pressure humidification system for **medium/large areas** in supermarkets

HUMIFOG



Medium pressure fog
230V-50Hz



Humidification kit for
Supermarket



Water inlet filter as standard, with 80micron AISI 304 stainless steel mesh. Works in conjunction with IT.0581 water supply Kit

Detail of the
sterilising lamp



Easy to use



Silent working



Pump free of maintenance



The perfect degree of humidity to preserve the freshness of fruit, vegetables, fish and flowers

Humi Fog is a humidification system specially designed to preserve the freshness of fruit, vegetables, fish and flowers. The nebulised water, **filtered** and **sterilised**, which is sprayed on the counters through nozzles arranged along a steel or polyamide line, rehydrates the food produce, preventing **dehydration** and reducing **weight loss**.

Humi Fog	Description	compatibility with Humidification kit		Price
		3m	6m	
	ZX.HF Module Humi Fog , 25l/h, 25bar, 125W, 230V-50Hz (complete with sterilising lamp)	•	•	€1.095,00*

Humidification kit	Description	line length in metres	
		3m	6m
	Polyamide pipe for high pressures ø6.35mm, (in metres)	ZX.KH3 25	ZX.KH6 25
	AISI 304 stainless steel pipe ø12mm 3000mm, 6 holes, pitch 500mm, complete with adjustable threaded adapters 10/24UNC/2A	1	2
	Rubberised stainless steel pipe clamp for fixing a polyamide pipe, ø6.35mm	35	35
	Pipe junction Slip-Lock quick coupling , straight, made of AISI 303 stainless steel for ø12mm pipes	-	1
	End of line cap Slip-Lock - in AISI 303 stainless steel for Slip-Lock ø12mm	1	1
	Pipe junction Slip-Lock quick coupling , straight, made of AISI 303 stainless steel, adapts from 12mm to ø6.35mm	1	1
	Fog nozzle in nickel-plated brass , cleanable, complete with anti-drip valve, 10/24UNC/2A thread, flow factor 015	6	12
	Tube cutter for polyamide pipe ø2-12mm	1	1
		€390,00*	€620,00*

Recommended accessories

	IT.0581 Water supply kit complete with mesh filter, and Fog module 3m water connection pipe	€19,80*		IT.0582 Anti-limescale filter with polyphosphate salts for water supply kit	€5,80*
---	--	----------------	---	--	---------------

Technical features

- **Voltage** 230V-50Hz
- **Water filter with SS cartridge**
- **Thermal protection fuse**
- **UV lamp 300**
- **Power absorbed (module+UV lamp) 125W**
- **Pump dimensions** 42x20x32cm
- **L.p. Slip-Lock inlet** ø9.6mm
- **Outlet, Slip-Lock** ø6.35mm

Adjustable timer:

- Work from 1 to 60 sec
- Pause from 1 to 60 min
- The system usually works according to a pause/work cycle, nebulising for a few seconds every 5-10 minutes, thus making actual consumption very low

Humi Fog consumption:

- **125W** working
- **12W** stand-by

HUMI Extra



Fog kit 60bar
230V-50Hz



Fog Extra to cool, humidify, suppress dust and odours and many more



Humidification kit for Supermarket



Water inlet filter as standard, with 80micron AISI 304 stainless steel mesh. Works in conjunction with IT.0581 water supply Kit



Detail of the sterilising lamp

NEW SAFETY SYSTEM:

in the event of a pipe break in the fog nozzle lines, the system automatically shuts down to prevent flooding of the areas where the lines are installed

The perfect degree of humidification to preserve the freshness of fruit, vegetables, fish and flowers

Humi Extra is a humidification system specially developed to preserve the freshness of fruit, vegetables, fish and flowers. The nebulised water, **filtered** and **sterilised**, which is sprayed on the counters through nozzles arranged along a steel or polyamide line, rehydrates the food produce, preventing **dehydration** and reducing **weight loss**.

The new control panel allows for quick and accurate setting of the work times and management of the connected optional probes.



Programmer (weekly)



Desired humidity (settable)



Keeps insects away

0 - Optionals
X - Not available

ZX.KM-EC	Maintenance kit 2 piston axial pump (valve kit and water seals kit for pump)	0	0	0	X	X	X	€48,70*
ZX.KM-AX	Maintenance kit 3 piston axial pump (valve kit and water seal kit for pump)	X	X	X	0	0	0	€70,90*
IT.0915	UV lamp 300	0	0	0	0	0	0	€117,00*
ZX.SU20	Moisture Probe for Fog Extra - 20m cable	0	0	0	0	0	0	€385,00*

Humi Extra	Description	compatibility with Humidification kit						Price
		3m	6m	9m	12m	15m	18m	
	ZX.HE-05	Fog Extra 0.5l/min 60bar complete with sterilising lamp	●					€1.845,00*
	ZX.HE-1	Fog Extra 1l/min 60bar complete with sterilising lamp		●	●			€1.965,00*
	ZX.HE-2	Fog Extra 2l/min 60bar complete with sterilising lamp				●	●	●

line length in metres

Humidification kit	Description	line length in metres						
		3m	6m	9m	12m	15m	18m	
	Polyamide pipe for high pressures, ø6.35mm (in metres)	ZX.KH3	ZX.KH6	ZX.KH9	ZX.KH12	ZX.KH15	ZX.KH18	
		25	25	25	25	25	25	
	Rubberised stainless steel pipe clamp for polyamide pipe fixing ø6.35mm	35	35	45	45	55	65	
	AISI 304 stainless steel pipe ø12mm 3000mm, 6 holes, pitch 500mm complete with adjustable threaded adapters 10/24UNC/2A	1	2	3	4	5	6	
	Pipe junction Slip-Lock quick coupling , straight, made of AISI 303 stainless steel for ø12mm pipes	-	1	2	3	4	5	
	Pipe quick coupling, "Tee" , in nickel-plated brass, ø6.35mm	-	-	1	1	1	1	
	End of line cap Slip-Lock in AISI 303 stainless steel for Slip-Lock ø12mm	1	1	2	2	2	2	
	Pipe junction Slip-Lock quick coupling , straight, made of AISI 303 stainless steel, adapts from 12mm to ø6.35mm	1	1	2	2	2	2	
	Tube cutter for polyamide pipe ø2-12mm	1	1	1	1	1	1	
	Fog nozzle in nickel-plated brass , complete with anti-drip valve and cleanable 50micron mesh filter, 10/24UNC/2A thread, flow factor 015	6	12	18	24	30	36	
		€390,00*	€620,00*	€940,00*	€1.170,00*	€1.410,00*	€1.650,00*	

Recommended accessories

	IT.0581	Water supply kit complete with mesh filter, and Fog module 3m water connection pipe	€19,80*		ZX.ST20	Humidity probe (for standard thermostat), with 20m cable	€83,40*
	IT.0582	Anti-limescale filter with polyphosphate salts for water supply kit	€5,80*		ZX.SU20	Humidity probe 4:20 mA (for standard humidstat), with 20m cable	€385,00*

Technical features

- **Frame** in painted steel sheet
- **Electric pump** 1450rpm, 230V-50Hz
- **Unloader valve**
- **Low pressure solenoid valve** 230V-50Hz, water inlet
- **High pressure solenoid valve** 230V-50Hz, to discharge line pressure
- **Electrical panel** complete with: ON/OFF thermal cutout, electronic board for management of anti-drip and timer system
- **Dimensions WxLxH: 600 x 300 x 300mm**
- **Slip-lock inlet** ø9.6mm
- **Outlet, Slip-Lock** ø6.35mm
- **High pressure switch** for no water supply and pipe breaks
- **Dimensions WxLxH: 600 x 300 x 300mm**

IDROBASE®

PASSION FOR WATER



EN - Ed. 2019 / Rev. 1

*TERMS OF SUPPLY

- Delivery: EX WORKS
- Packing: NOT INCLUDED
- Our prices are quoted excluding VAT
- Specifications, data, tables and illustrations are provided for guidance only. Idrobase Group s.r.l. reserves the right to make changes without prior notice.
- The list prices will be reviewed monthly and may be subject to changes due to continuous market fluctuations.



idrobase®

Innovative pressure washers

idrobase.it



club dei riparatori®

The winning solution to manufacture and repair all kinds of pressure washers

clubdeiriparatori.it



Enjoy your life
Night & Day

enjoyyourfurniture.com



idrotech®

Tailor-made misting systems

idrotech.com



club del misting®

The winning solution to manufacture and repair all kinds of misting systems

clubdelmisting.com

Idrobase Group s.r.l.

35010 BORGORICCO (PD) ITALIA - Via dell'Industria, 25

+39 049 9335903 +39 049 9335922

info@idrobasegroup.com

www.idrobasegroup.com

