

## VODIACE KRÚŽKY

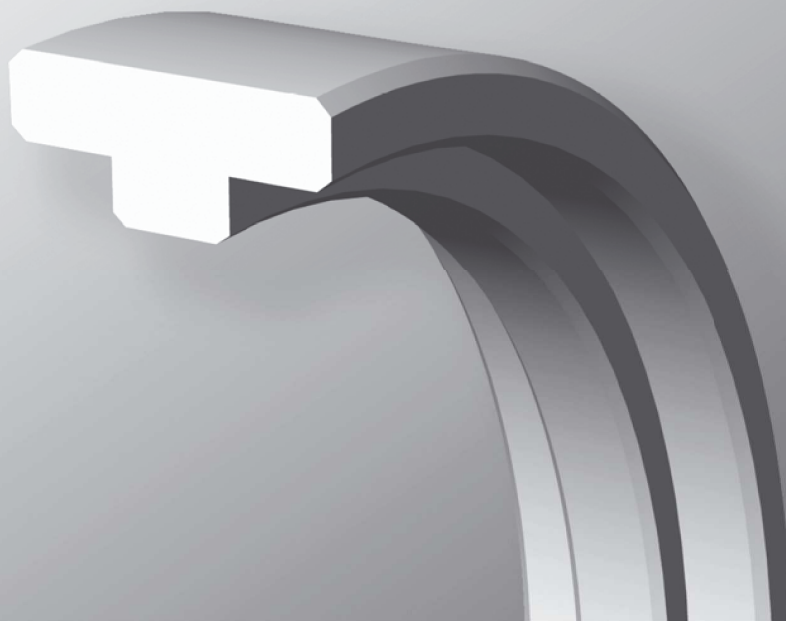

- NÍZKE VÝROBNÉ A SERVISNÉ NÁKLADY
- VOĽBA PROFILOV NA ZÁKLADE FUNKČNÝCH PARAMETROV
- JEDNODUCHÁ INŠTALÁCIA

**ZÁSTAVBOVÝ PRIESTOR pre piestnicu**

Objednávka profilov: DF 101, 102

**PRÍKLAD OBJEDNÁVKY**

DF101 - 40x50x10/9,8 POM

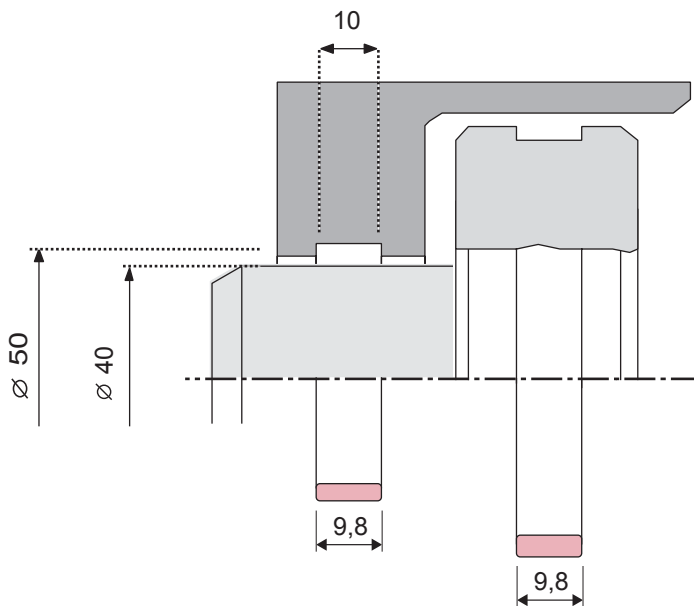
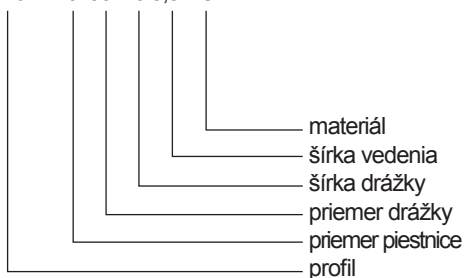



**ZÁSTAVBOVÝ PRIESTOR pre piest**

Objednávka profilov: DF 103 - 108

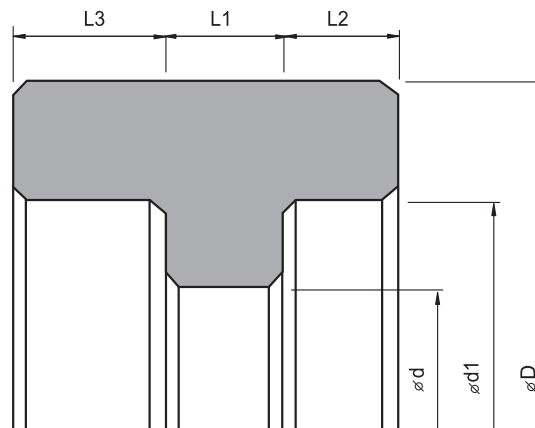
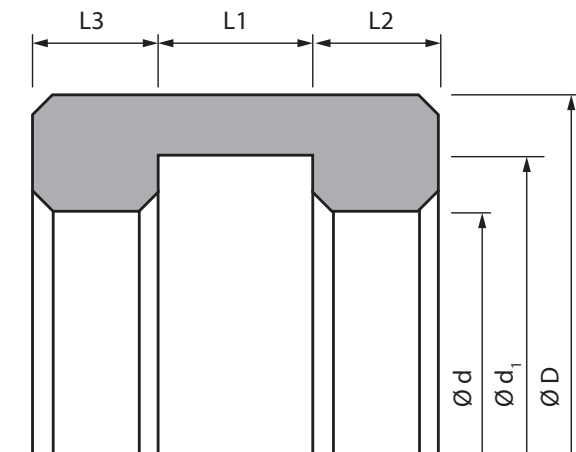
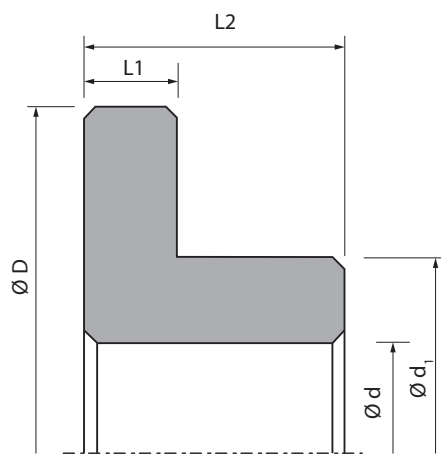
*V prípade zložitejších tvarov vodiacich krúžkov uveďte vo vašej objednávke náčrt s uvedením rozmerov:*

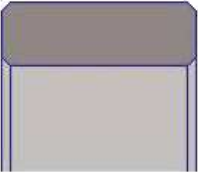

Tento katalóg podlieha zmenovej službe 01/16

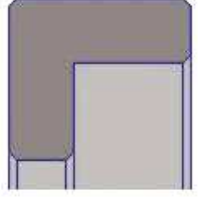
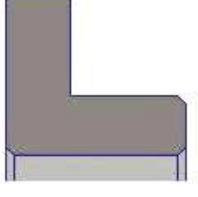
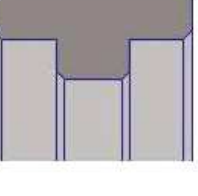
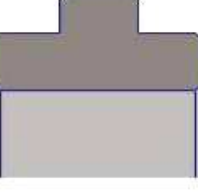
Profil	Značenie	Popis	Materiál	Teplota (°C)	Tlak (N/mm <sup>2</sup> )	Rýchlosť (m/s)
	DF 101	Vodiaci krúžok so zrazenými hranami pre piestnicové, piestne aplikácie. Delený je možné použiť aj do uzavretých drážok.	POM	- 40 +100	25,0	4,0
			PTFE I	- 200 +200	3,0	4,0
			PTFE II	- 200 +200	4,5	5,0
			PTFE III	- 200 +200	5,0	5,0
	DF 102	Vodiaci krúžok s ostrou hranou.	POM	- 40 +100	25,0	4,0
			PTFE I	- 200 +200	3,0	4,0
			PTFE II	- 200 +200	4,5	5,0
			PTFE III	- 200 +200	5,0	5,0
	DF 103	Uhlový vodiaci a oporný krúžok pre piest. Delené aj nedelené prevedenie.	POM	- 40 +100	25,0	4,0
			PTFE I	-200 +200	3,0	4,0
			PTFE II	-200 +200	4,5	5,0
			PTFE III	-200 +200	5,0	5,0
	DF 104	Uhlový vodiaci a oporný krúžok pre piestnicu. Delené aj nedelené prevedenie.	POM	- 40 +100	25,0	4,0
			PTFE I	-200 +200	3,0	4,0
			PTFE II	-200 +200	4,5	5,0
			PTFE III	-200 +200	5,0	5,0
	DF 105	Krúžok typu "T" pre piest.	POM	- 40 +100	25,0	4,0
			PTFE I	- 200 +200	3,0	4,0
			PTFE II	- 200 +200	4,5	5,0
			PTFE III	- 200 +200	5,0	5,0
	DF 106	Krúžok typu "T" pre piestnicu.	POM	- 40 +100	25,0	4,0
			PTFE I	- 200 +200	3,0	4,0
			PTFE II	- 200 +200	4,5	5,0
			PTFE III	- 200 +200	5,0	5,0

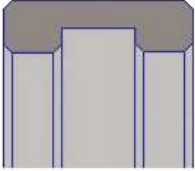
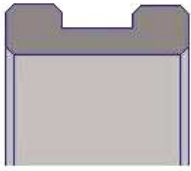
Profil	Značenie	Popis	Materiál	Teplota (°C)	Tlak (N/mm <sup>2</sup> )	Rýchlosť (m/s)
	DF 107	Vodiaci krúžok pre piest s vnútornou drážkou.	POM	-40 +100	25,0	4,0
			PTFE I	- 200 +200	3,0	4,0
			PTFE II	- 200 +200	4,5	5,0
			PTFE III	- 200 +200	5,0	5,0
	DF 108	Vodiaci krúžok pre piestnicu s vonkajšou drážkou.	POM	- 40 +100	25,0	4,0
			PTFE I	- 200 +200	3,0	4,0
			PTFE II	- 200 +200	4,5	5,0
			PTFE III	- 200 +200	5,0	5,0