

Kluzná pouzdra s přírubou

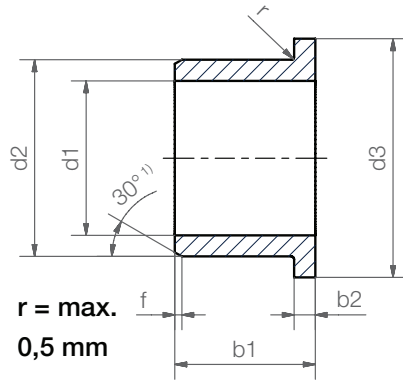

Objednací klíč

ZFM-0405-04



Délka b1
Vnější průměr d2
Vnitřní průměr d1
Metrický
Typ (tvar F)
Materiál iglidur® Z

Rozměry dle normy ISO 3547-1 a speciálních rozměrů

¹⁾ tloušťka stěny < 1 mm: zkosení = 20°

Zkosení ve vztahu k d1

d1 [mm]:	Ø 1-6	Ø 6-12	Ø 12-30	Ø > 30
f [mm]:	0,3	0,5	0,8	1,2

Rozměry [mm]

Číslo dílu	d1	d1-Tolerance*	d2	d3 d13	b1 h13	b2 -0,14
ZFM-0405-04	4,0	+0,010 +0,058	5,5	9,5	4,0	0,75
ZFM-0507-05	5,0	+0,010 +0,058	7,0	11,0	5,0	1,0
ZFM-0608-08	6,0	+0,010 +0,058	8,0	12,0	8,0	1,0
ZFM-0810-055	8,0	+0,013 +0,071	10,0	15,0	5,5	1,0
ZFM-0810-09	8,0	+0,013 +0,071	10,0	15,0	9,0	1,0
ZFM-1012-05	10,0	+0,013 +0,071	12,0	18,0	5,0	1,0
ZFM-1012-09	10,0	+0,013 +0,071	12,0	18,0	9,0	1,0
ZFM-1012-15	10,0	+0,013 +0,071	12,0	18,0	15,0	1,0
ZFM-101315-05	10,0	+0,013 +0,071	13,0	15,0	5,5	1,5
ZFM-1214-09	12,0	+0,016 +0,086	14,0	20,0	9,0	1,0
ZFM-1214-12	12,0	+0,016 +0,086	14,0	20,0	12,0	1,0
ZFM-1214-20	12,0	+0,016 +0,086	14,0	20,0	20,0	1,0
ZFM-1416-17	14,0	+0,016 +0,086	16,0	22,0	17,0	1,0
ZFM-1517-11	15,0	+0,016 +0,086	17,0	23,0	11,0	1,0
ZFM-1517-15	15,0	+0,016 +0,086	17,0	23,0	15,0	1,0
ZFM-151723-23	15,0	+0,016 +0,086	17,0	23,0	23,0	1,0
ZFM-1618-12	16,0	+0,016 +0,086	18,0	24,0	12,0	1,0
ZFM-1820-04	18,0	+0,016 +0,086	20,0	26,0	4,0	1,0
ZFM-1820-17	18,0	+0,016 +0,086	20,0	26,0	17,0	1,0
ZFM-2022-21	20,0	+0,020 +0,104	22,0	30,0	21,0	1,0
ZFM-2023-11	20,0	+0,020 +0,104	23,0	30,0	11,5	1,5
ZFM-2023-155	20,0	+0,020 +0,104	23,0	30,0	15,5	1,5
ZFM-2023-16	20,0	+0,020 +0,104	23,0	30,0	16,5	1,5
ZFM-2023-21	20,0	+0,020 +0,104	23,0	30,0	21,5	1,5
ZFM-2023-31	20,0	+0,020 +0,104	23,0	30,0	31,5	1,5

* po zalisování. Kontrolní metody, ► strana 75



dodací ze skladu ve
termín výrobním závodě