

Linear robot - for vertical working planes

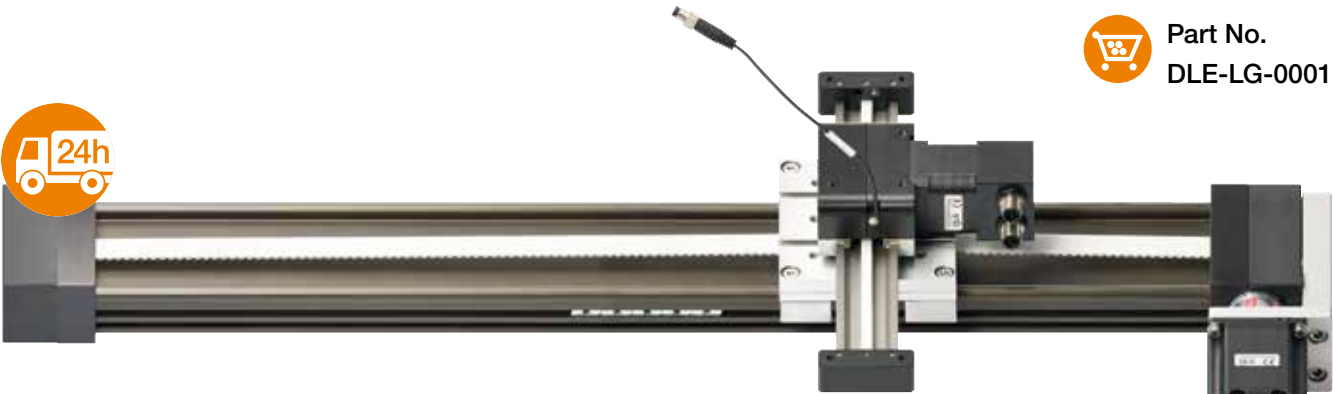

Part No.
DLE-LG-0001



- **x-axis:** drylin® GRW-0630 rack and pinion drive with NEMA17 stepper motor with encoder
- **y-axis:** drylin® ZLW-1080 toothed belt axis with NEMA23 stepper motor with encoder
- Proximity switches, connection cables, control systems and other installation sizes upon request



igus® Robot Control
► From page 718

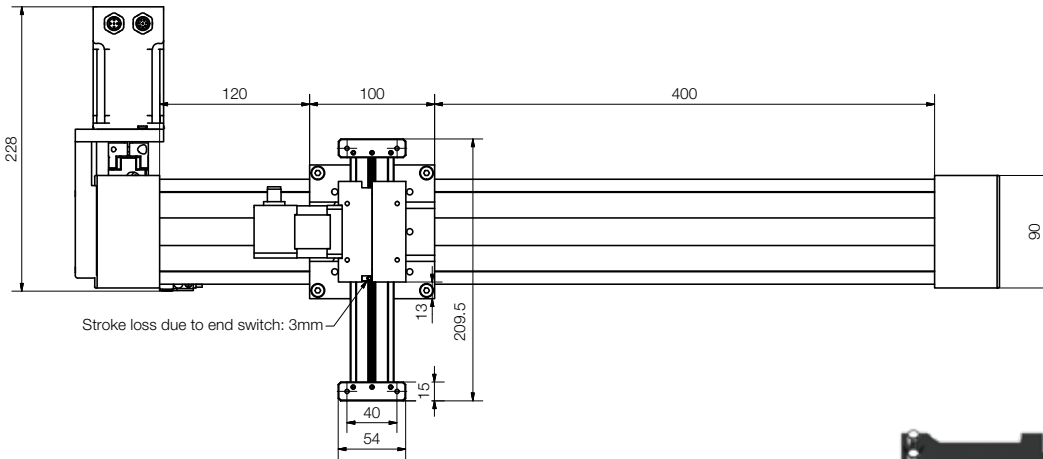

Part No.
DLE-LG-0002

- **y-axis:** drylin® ZLW-10120 toothed belt axis with NEMA 23 XL stepper motor with encoder
- **z-axis:** GRR-1280 rack axis with NEMA23 XL stepper motor with encoder
- Proximity switches and motor cables available

Technical data

		DLE-LG-0001	DLE-LG-0002
Workspace ¹⁸¹⁾	[mm]	500 x 100	800 x 500
Max. speed	[m/s]	1.0	1.0
Max. acceleration	[m/s ²]	3.0	2.0
Repeatability	[mm]	0.2	0.3
Max. load capacity	[N]	25.0	50.0

¹⁸¹⁾ Customised stroke length upon request