



MAGNETROL®

TOP MOUNTING

Liquid Float Level Switches

DESCRIPTION

T20 and T21 units are simple, reliable float switches designed for top mounting into tanks or vessels. T20 units utilize a single switch mechanism and float. T21 units utilize two switch mechanisms and two separate floats when widely spaced actuating levels are required. T20 and T21 models are available for any type of open or closed vessel with either threaded or flanged type mounting and actuating depths up to 1219 mm (48 inches).

FEATURES

- Carbon or stainless steel process connection materials (other materials available at request)
- Flanged and threaded process connections
- Wide choice of housings and switch mechanisms
- Process temperature up to 540 °C (1000 °F)
- Up to 2 switch levels (T21)
- Specific gravity as low as 0,60
- Process pressure up to 41,3 bar (600 psi)
- Standard anti corrosive protection
- Custom calibrated
- Suited for SIL 2 loops (DPDT switch)



Optional:

- NACE construction
- Interface calibration
- Special tank connections
- Elevated temperature
- Special exterior surface preparation and finish
- Stilling well
- Tropicalized switch mechanism
- Submersible housing

APPLICATIONS

- Day Tanks
- Condensate Receivers
- Fuel Storage Tanks
- Cooling Towers
- Flash Tanks
- Interface
- High and high/high alarm from single tank entry

Float level switches for single or dual level alarm



PRINCIPLE OF OPERATION

A permanent magnet ① is attached to a pivoted switch actuator and adjustment screw ②. As the float ③ rises following the liquid level, it raises the attraction sleeve ④ into the field of the magnet, which then snaps against the non-magnetic enclosing tube ⑤, actuating the switch ⑥. The enclosing tube provides a static pressure boundary between the switch mechanism and the process. On a falling level, an inconel spring retracts the magnet, deactivating the switch.

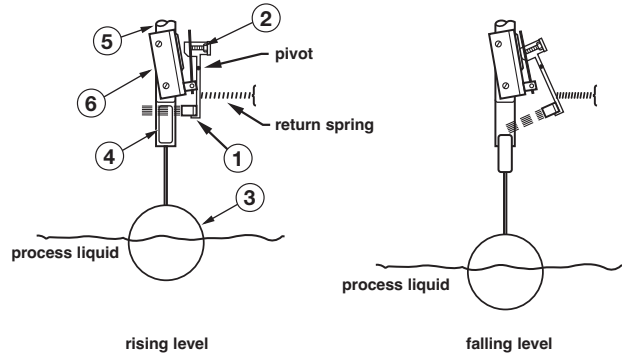

MOUNTING

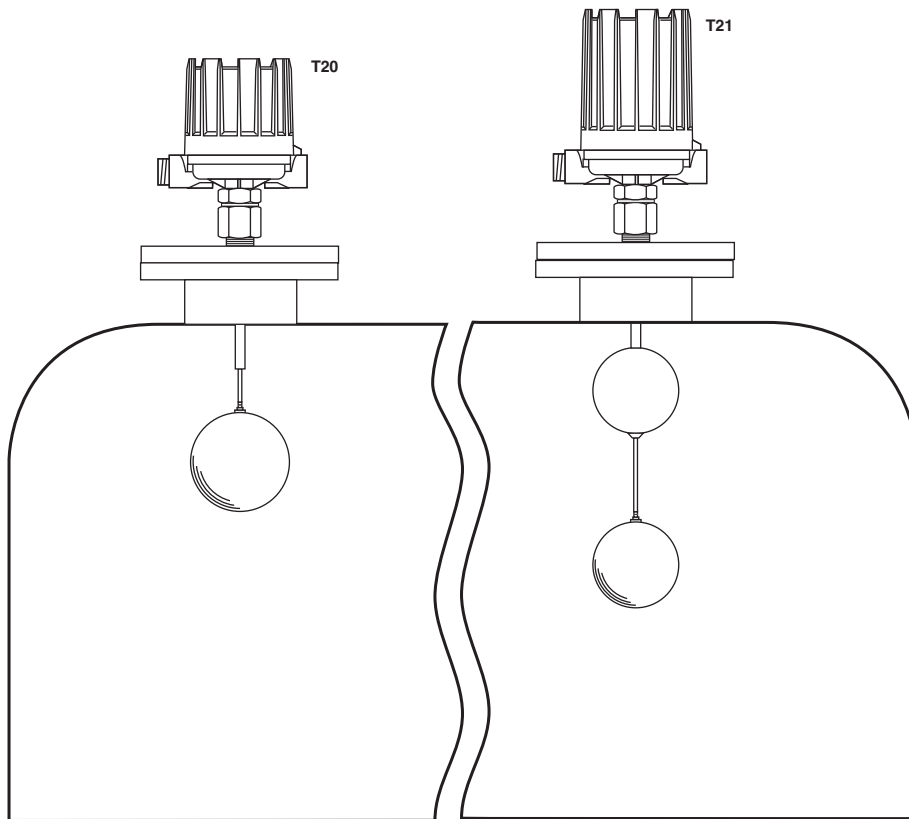

T20 – SINGLE SWITCH MODEL

Level alarm applications
Narrow differential type







These instruments are factory calibrated to operate over a narrow level differential band and are ideally suited for liquid level alarm applications, on either high or low level.

T21 – DUAL SWITCH MODEL

Level alarm applications
Narrow differential type

T21 tandem models combine the functions of two separate narrow differential level controls in a single, compact, easy to install instrument. Two individual switch mechanisms are employed to provide two actuating levels at least 203 mm (8") apart. These instruments are ideally used in applications requiring two separate switching points, such as high and low level alarm operation.

AGENCY APPROVALS

| AGENCY | APPROVED MODEL | AREA CLASSIFICATION |
|--|---|---|
| ATEX  | All with electric switch mechanism and housing listed as ATEX Ex d | ATEX II 2 G Ex d IIC T6 Gb |
| | All with electric switch mechanism and housing listed as ATEX Ex ia | ATEX II 1 G Ex ia IIC T6 Ga |
| FM  | All with electric switch mechanism and housing listed as NEMA 7/9 | Class I, Div 1, groups C & D Class II, Div 1, Groups E, F & G |
| | Consult factory for proper model numbers | Class I, Div 1, groups B, C & D Class II, Div 1, Groups E, F & G |
| IECEX  | All with electric switch mechanism and housing listed as IECEX Ex d | Ex d IIC T6 |
| | All with electric switch mechanism and housing listed as IECEX Ex ia | Ex ia IIC T6 Ga |
| CSA  | Consult factory for proper model numbers | Class I, Div 1, groups C & D Class II, Div 1, Groups E, F & G |
| | Consult factory for proper model numbers | Class I, Div 1, groups B, C & D Class II, Div 1, Groups E, F & G |
| EAC (Russia, Kazakhstan, Belarus)  | All with electric switch mechanism and housing listed as ATEX Ex d | 1Ex d IIC T6 Gb |
| | All with electric switch mechanism and housing listed as ATEX Ex ia | 0Ex ia IIC T4 Ga |
| LRS  | Lloyds Register of Shipping | Marine approval |
| CE  | The units are conform to the ATEX directive 2014/34/EU, The PED directive 2014/68/EU and the Low Voltage Directive 2014/35/EU | |
| Other approvals are available, consult factory for more details | | |

SWITCH MECHANISMS AND HOUSINGS

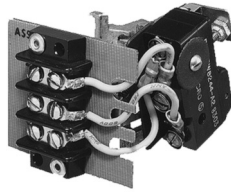

Series B, C, D, R & U Dry contact switches ^①

- Series B and C switches are general purpose units with a selection of maximum liquid temperature ratings
- Series D switch is designed for high DC current applications
- Series U switches have gold alloy contacts
- Series R switches are designed for the highest temperature applications up to +540 °C (+1000 °F)



Series HS ^②, F, W, X, 8 & 9 Hermetically sealed switches

- Entire mechanism and contacts are contained within a positively pressurized capsule with series HS
- Ideal for use in salt and other corrosive atmospheres

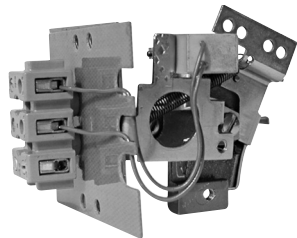

Series V Inductive Proximity switch ^④

- Series V switches are inductive proximity switches type SJ3,5-SN with a maximum liquid temperature rating of +100 °C (+210 °F)



Series J & K Pneumatic switches ^③

- Suited for process industry applications in hazardous locations or where electrical power is not available
- Series J bleed type switch is intended for general purpose applications
- Series K switch is specially designed to provide non-bleed operation with a high degree of vibration resistance



Switch housings ^①

- Die cast aluminium housings
- Cast iron housings
- Stainless steel housings
- Optional housing heaters and drains available for some housings
- Pneumatic switch mechanisms available with alu base/cold rolled steel cover
- Electrical switch mechanisms for high temperature available with aluminium base / cold rolled steel cover

Basic electrical ratings (for more details see bulletin BE 42-683)

| Voltage | Switch Series and Non-Inductive Ampere Rating | | | | | | | | | | |
|----------|---|-------|-------|------|------|------|------|------|------|------|------|
| | B | C | D | F | HS | R | U | W | X | 8 | 9 |
| 120 V AC | 15.00 | 15.00 | 10.00 | 2.50 | 5.00 | 1.00 | 1.00 | 1.00 | 0.50 | 1.00 | 1.00 |
| 240 V AC | 15.00 | 15.00 | — | — | 5.00 | 1.00 | — | 1.00 | 0.50 | — | — |
| 24 V DC | 6.00 | 6.00 | 10.00 | 4.00 | 5.00 | 1.00 | 1.00 | 3.00 | 0.50 | 3.00 | 1.00 |
| 120 V DC | 0.50 | 1.00 | 10.00 | 0.30 | 0.50 | 0.40 | — | 0.50 | 0.50 | — | — |
| 240 V DC | 0.25 | 0.50 | 3.00 | — | 0.25 | — | — | — | — | — | — |

^① For more details see bulletin BE 42-683

^② For more details on HS Hermetically sealed switches, see bulletin BE 42-694

^③ For more details on J & K Pneumatic switches, see bulletin BE 42-685 and bulletin BE 42-686

^④ For more details on V Inductive Proximity switches, see bulletin BE 42-798

DIMENSIONS IN mm (inches)

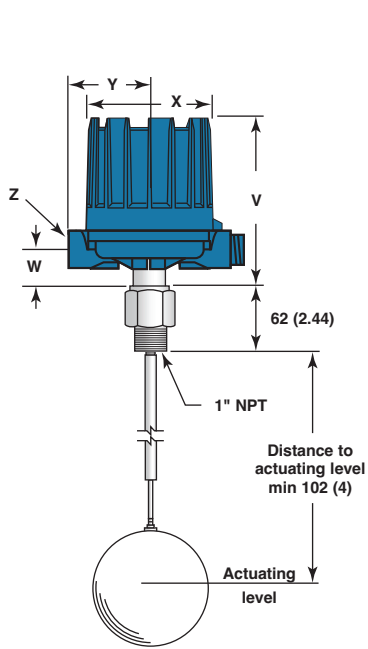

Model T20 with 1" NPT

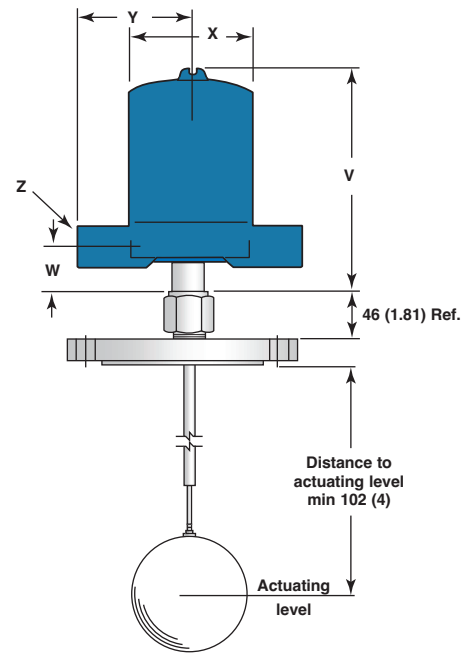

Model T20 with flange

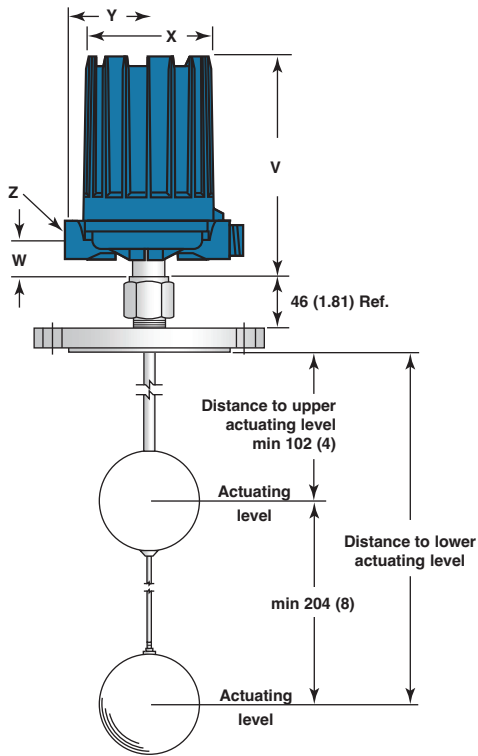

Model T21 with flange

| Distance to | Maximum | Minimum |
|-------------|---------------|-----------|
| Upper level | 1016 mm (40") | 102 (4") |
| Lower level | 1219 mm (48") | 305 (12") |

Note: On model T21, the lower float actuates the upper switch mechanism. The upper float actuates the lower switch mechanism.

| Housing type | Models | V | W | ø X | Y | Z |
|--|---------------------|-------------|-----------|------------|------------|---|
| Weatherproof-FM (NEMA 7/9) - ATEX (Cast Alu) | T21 | 257 (10.12) | 42 (1.66) | 151 (5.93) | 109 (4.29) | M20 x 1,5 (*) or 1" NPT (2 entries - 1 plugged) (*) not for FM (NEMA 7/9) |
| | T20 with HS-switch | | | | | |
| | T20 excl. HS-switch | | | | | |
| Weatherproof (CS/Aluminium) | T20 | 165 (6.50) | 39 (1.54) | 118 (4.65) | 83 (3.27) | 3/4" NPT (single entry) |
| | T21 | 216 (8.50) | | | | |
| ATEX (Cast Iron) | All | 249 (9.80) | 45 (1.77) | 143 (5.63) | 110 (4.33) | M20 x 1,5 or 3/4" NPT (single entry - 2 entries at request) |
| Pneumatics Series J Bleed Type | T20 | 165 (6.50) | 39 (1.54) | 118 (4.65) | 110 (4.33) | 1/4" NPT |
| Pneumatics Series K Non Bleed | | | | | 130 (5.12) | |

Allow 200 mm (7.87") overhead clearance / All housings are 360 ° rotatable

EXPEDITE SHIP PLAN (ESP)

Several models are available for quick shipment, within max. 4 weeks after factory receipt of purchase order, through the Expedite Ship Plan (ESP). To take advantage of ESP, simply match the blue model number codes.

ESP delivery is limited to a maximum of 10 units per order. Contact your local representative for lead times on larger volume orders, as well as other products and options.

SELECTION DATA T20 SINGLE SWITCH

A complete measuring system consists of:

Order code for **T20** models (each unit is factory calibrated to operate on a given specific gravity within the min and the max values listed per model)

MODEL NUMBER CODE AND MATERIALS OF CONSTRUCTION

| Model No. | Set points | Process /Tank connection | Float and trim | Magnetic sleeve |
|-----------|------------------|--------------------------|------------------|------------------|
| T20-A | 1 - Single float | Carbon steel | 316 SST (1.4401) | 400 series SST |
| T20-B | | | | 316 SST (1.4401) |
| T20-D | | 316 SST (1.4401) | | |

Important: Actuating level, in either the rising or falling state, and specific gravity must be provided upon placement of order. The maximum available actuating level is governed by the liquid specific gravity and selected float size as given in the table below. The minimum actuating level is 102 mm (4 inches).

FLOAT SELECTION AND MAX ACTUATING LEVEL ^①

| Liquid Specific Gravity | Float Size mm (inches) | | | |
|-------------------------|------------------------|--------------------------|------------|----------------|
| | Ø 76 x 127 (3" x 5") | Ø 89 x 152 (3 1/2" x 6") | Ø 102 (4") | Ø 114 (4 1/2") |
| 1,00 | 991 (39) | 1219 (48) | 1219 (48) | 1219 (48) |
| 0,90 | 508 (20) | 1219 (48) | 838 (33) | 1219 (48) |
| 0,80 | — | 1219 (48) | 279 (11) | 1219 (48) |
| 0,70 | — | 838 (33) | — | 965 (38) |
| 0,60 | — | — | — | 152 (6) |

^① The minimum actuation level is 102 mm (4")

FLOAT PRESSURE RATINGS

| Float Size mm (inches) | Pressure Rating bar (PSIG) | | | |
|--------------------------|----------------------------|-----------------|------------------------------|-------------------------------|
| | 40 °C (100 °F) | 400 °C (750 °F) | 480 °C ^① (900 °F) | 540 °C ^① (1000 °F) |
| Ø 76 x 127 (3" x 5") | 34,4 (500) | 26,0 (377) | 24,3 (353) | 23,1 (335) |
| Ø 89 x 152 (3 1/2" x 6") | 34,4 (500) | 27,7 (403) | 26,7 (388) | 26,4 (383) |
| Ø 102 (4") | 41,3 (600) | 33,3 (483) | 32,0 (465) | 31,6 (459) |
| Ø 114 (4 1/2") | 34,4 (500) | 27,7 (403) | 26,7 (388) | 26,4 (383) |

^① Upon prolonged exposure to temperatures above 425 °C (800 °F), the carbide phase of steel may be converted to graphite. Permissible but not recommended for prolonged use above 425 °C (800 °F). (Applies to models T20-A & T20-B.)

TANK CONNECTION AND FLOAT SIZE

| Tank Connection | Float sizes | | | |
|--------------------------|---------------------------------------|---------------|-------------------|-----------------------------|
| | Ø 76 x 127 mm (3" x 5") | Ø 102 mm (4") | Ø 114 mm (4 1/2") | Ø 89 x 152 mm (3 1/2" x 6") |
| | Threaded NPT connection | | | |
| 1" NPT | B2A | B2B | B2C | B2D |
| | ASME Flanges ^① | | | |
| 4" 150 lbs RF | H3A | — | — | H3D ^② |
| 4" 300 lbs RF | H4A | — | — | H4D ^② |
| 5" 150 lbs RF | J3A | J3B | J3C ^② | J3D |
| 5" 300 lbs RF | J4A | J4B | J4C ^② | J4D |
| 6" 150 lbs RF | K3A | K3B | K3C | K3D |
| 6" 300 lbs RF | K4A | K4B | K4C | K4D |
| 8" 150 lbs RF | L3A | L3B | L3C | L3D |
| | EN 1092-1 flanges ^① | | | |
| DN 100 PN16, Type B1 | 8FA | — | — | 8FD ^② |
| DN 100 PN 25/40, Type B1 | 8GA | — | — | 8GD ^② |
| DN 150 PN16, Type B1 | 9FA | 9FB | 9FC | 9FD |
| DN 150 PN 25/40, Type B1 | 9GA | 9GB | 9GC | 9GD |

^① Flanges are threaded onto 1" NPT bushing

^② Float cannot pass S160 nozzle or greater

SWITCH MECHANISM & HOUSING (next page)

T 2 0 — — — — — **complete order code for T20 models**

X = product with a specific customer requirement

SELECT ELECTRIC SWITCH MECHANISM & HOUSING

| Switch Description | Process ^① Temperature Range °C (°F) | Contacts | T20-A Models | | | | | | | | | T20-B and T20-D Models | | | | | | | | |
|---|--|----------|-----------------------|----------------------|----------------|-----------------------|-----------------------|-----------|----------------|-----------------------|-----------------------|------------------------|----------------|-----------|-----------------------|--------|---------|------------|-----|-----|
| | | | Weather proof (IP 66) | ATEX - IECEx (IP 66) | | | | | | FM (IP 66) | Weather proof (IP 66) | ATEX - IECEx (IP 66) | | | | | | FM (IP 66) | | |
| | | | | II 2G Ex d IIC T6 Gb | | | II 1G Ex ia IIC T6 Ga | | | NEMA 7/9 | | II 2G Ex d IIC T6 Gb | | | II 1G Ex ia IIC T6 Ga | | | NEMA 7/9 | | |
| | | | | Cast Aluminium | Cast Aluminium | Cast Iron (ATEX only) | Cast Aluminium | Cast Alu. | Cast Aluminium | Cast Aluminium | | Cast Iron (ATEX only) | Cast Aluminium | Cast Alu. | | | | | | |
| M20x1,5 | 1" NPT | M20x1,5 | 1" NPT | M20x1,5 | 3/4" NPT | M20x1,5 | 1" NPT | 1" NPT | M20x1,5 | 1" NPT | M20x1,5 | 1" NPT | M20x1,5 | 3/4" NPT | M20x1,5 | 1" NPT | 1" NPT | | | |
| Series B Snap switch | -40 to +120 (-40 to +250) | 1x SPDT | B2P | BAP | BHC | BAC | BK7 | BU7 | – | – | BKP | B2Q | BAQ | BH9 | BA9 | BK5 | BU5 | – | – | BKQ |
| | | 1x DPDT | B8P | BDP | BJC | BBC | BD7 | BW7 | – | – | BNP | B8Q | BDQ | BJ9 | BB9 | BD5 | BW5 | – | – | BNQ |
| Series C Snap switch | -40 to +230 (-40 to +450) | 1x SPDT | C2P | CAP | CHC | CAC | CK7 | CU7 | C2L | CAL | CKP | C2Q | CAQ | CH9 | CA9 | CK5 | CU5 | C2S | CAS | CKQ |
| | | 1x DPDT | C8P | CDP | CJC | CBC | CD7 | CW7 | C8L | CDL | CNP | C8Q | CDQ | CJ9 | CB9 | CD5 | CW5 | C8S | CDS | CNQ |
| Series D DC Current Snap switch | -40 to +120 (-40 to +250) | 1x SPDT | D2Q | DAQ | DH9 | DA9 | DK5 | DU5 | – | – | DKQ | D2Q | DAQ | DH9 | DA9 | DK5 | DU5 | – | – | DKQ |
| | | 1x DPDT | D8Q | DDQ | DJ9 | DB9 | DD5 | DW5 | – | – | DNQ | D8Q | DDQ | DJ9 | DB9 | DD5 | DW5 | – | – | DNQ |
| Series F Hermetically sealed Snap switch | -45 to +400 (-50 to +750) | 1x SPDT | F2P | FAP | FHC | FAC | FK7 | FU7 | – | – | FKP | F2Q | FAQ | FH9 | FA9 | FK5 | FU5 | – | – | FKQ |
| | | 1x DPDT | F8P | FDP | FJC | FBC | FD7 | FW7 | – | – | FNP | F8Q | FDQ | FJ9 | FB9 | FD5 | FW5 | – | – | FNQ |
| Series HS Hermetically sealed Snap switch | -45 to +290 ^② (-50 to +550) | 1x SPDT | H7A | HM2 | HFC | HA9 | HB3 | HB4 | – | – | HM3 | H7A | HM2 | HFC | HA9 | HB3 | HB4 | – | – | HM3 |
| | | 1x DPDT | H7C | HM6 | HGC | HB9 | HB7 | HB8 | – | – | HM7 | H7C | HM6 | HGC | HB9 | HB7 | HB8 | – | – | HM7 |
| Series U Gold alloy contacts Snap switch | -40 to +120 (-40 to +250) | 1x SPDT | U2P | UAP | UHC | UAC | UK7 | UU7 | U2L | UAL | UKP | U2Q | UAQ | UH9 | UA9 | UK5 | UU5 | U2S | UAS | UKQ |
| | | 1x DPDT | U8P | UDP | UJC | UBC | UD7 | UW7 | U8L | UDL | UNP | U8Q | UDQ | UJ9 | UB9 | UD5 | UW5 | U8S | UDS | UNQ |
| Series V Inductive Proximity switch | -40 to +100 (-40 to +210) | – | – | – | – | – | – | VFS | VHS | – | – | – | – | – | – | – | – | V5S | VBS | – |
| Series W Hermetically sealed Silver plated contacts Snap switch | -45 to +230 (-50 to +450) | 1x SPDT | W2P | WAP | WHC | WAC | WK7 | WU7 | W2L | WAL | WKP | W2Q | WAQ | WH9 | WA9 | WK5 | WU5 | W2S | WAS | WKQ |
| | | 1x DPDT | W8P | WDQ | WJ9 | WB9 | WD5 | WW5 | W8S | WDS | WNQ | W8Q | WDQ | WJ9 | WB9 | WD5 | WW5 | W8S | WDS | WNQ |
| Series X Hermetically sealed Gold plated contacts Snap switch | -45 to +230 (-50 to +450) | 1x SPDT | X2P | XAP | XHC | XAC | XK7 | XU7 | X2L | XAL | XKP | X2Q | XAQ | XH9 | XA9 | XK5 | XU5 | X2S | XAS | XKQ |
| | | 1x DPDT | X8P | XDQ | XJ9 | XB9 | XD5 | XW5 | X8S | XDS | XNQ | X8Q | XDQ | XJ9 | XB9 | XD5 | XW5 | X8S | XDS | XNQ |
| Series R High temperature Snap switch | -40 to +400 (-40 to +750) | 1x SPDT | R2Q | R1Q | RH9 | RA9 | RK5 | RU5 | – | – | RKQ | R2Q | R1Q | RH9 | RA9 | RK5 | RU5 | – | – | RKQ |
| | | 1x DPDT | R8Q | RDQ | RJ9 | RB9 | RN5 | RF5 | – | – | RNQ | R8Q | RDQ | RJ9 | RB9 | RN5 | RF5 | – | – | RNQ |
| Series 8 Hermetically sealed Snap switch | -45 to +400 (-50 to +750) | 1x SPDT | 82P | 8AP | 8HC | 8AC | 8K7 | 8U7 | – | – | 8KP | 82Q | 8AQ | 8H9 | 8A9 | 8K5 | 8U5 | – | – | 8KQ |
| | | 1x DPDT | 88P | 8DP | 8JC | 8BC | 8D7 | 8W7 | – | – | 8NP | 88Q | 8DQ | 8J9 | 8B9 | 8D5 | 8W5 | – | – | 8NQ |
| Series 9 High temperature Hermetically sealed Snap switch | -45 to +400 (-50 to +750) | 1x SPDT | 92P | 9AP | 9HC | 9AC | 9K7 | 9U7 | – | – | 9KP | 92Q | 9AQ | 9H9 | 9A9 | 9K5 | 9U5 | – | – | 9KQ |
| | | 1x DPDT | 98P | 9DP | 9JC | 9BC | 9D7 | 9W7 | – | – | 9NP | 98Q | 9DQ | 9J9 | 9B9 | 9D5 | 9W5 | – | – | 9NQ |
| Switch Description | Process ^① Temperature Range °C (°F) | Contacts | Weather proof (IP 65) | ATEX (IP 66) | | | | | | Weather proof (IP 65) | ATEX (IP 66) | | | | | | | | | |
| | | | | II 2G Ex d IIC T6 Gb | | | | | | | II 2G Ex d IIC T6 Gb | | | | | | | | | |
| | | | | CS/Aluminium | | | Cast Iron | | | | CS/Aluminium | | | Cast Iron | | | | | | |
| | | | | 3/4" NPT | | | M20x1,5 | | | | 3/4" NPT | | | 3/4" NPT | | | M20x1,5 | | | |
| Series R High temperature Snap switch | -40 to +540 ^③ (-40 to +1000) | 1x SPDT | R1Y | | | RK5 | | | RU5 | | | R1Y | | | RK5 | | | RU5 | | |
| | | 1x DPDT | RDY | | | RN5 | | | RF5 | | | RDY | | | RN5 | | | RF5 | | |
| Series 9 High temperature Hermetically sealed Snap switch | -40 to +540 ^③ (-40 to +1000) | 1x SPDT | 9AR | | | 9K7 | | | 9U7 | | | 9AY | | | 9K5 | | | 9U5 | | |
| | | 1x DPDT | 9DR | | | 9D7 | | | 9W7 | | | 9DY | | | 9D5 | | | 9W5 | | |

SELECT PNEUMATIC SWITCH MECHANISM & HOUSING

| Switch Description | Max supply pressure bar (psi) | Max liquid temperature ^① °C (°F) | Bleed orifice Ø mm (inches) | NEMA 3R (IP 53) | |
|---------------------------|-------------------------------|---|-----------------------------|-----------------|----------------------|
| | | | | T20-A Models | T20-B & T20-D Models |
| Series J (open air) | 6,9 (100) | 200 (400) | 1,60 (0.063) | JDG | JDE |
| | 4,1 (60) | | 2,39 (0.094) | JEG | JEE |
| | 4,1 (60) | 370 (700) | 1,40 (0.055) | JFG | JFE |
| Series K (closed circuit) | 6,9 (100) | 200 (400) | – | KOE | KOE |
| | 2,8 (40) | | – | KOG | – |

① Process temperature based on max. 40 °C (100 °F) ambient temperature and for non steam applications.
 ② On steam applications, temperature down-rated to +200 °C (+400 °F) process at +40 °C (+100 °F) ambient.
 ③ Upon prolonged exposure to temperatures above 425 °C (800 °F), the carbide phase of steel may be converted to graphite. Permissible but not recommended for prolonged use above 425 °C (800 °F). (Applies to models T20-A & T20-B.)

SELECTION DATA T21 DUAL SWITCH

A complete measuring system consists of:

Order code for **T21** models (each unit is factory calibrated to operate on a given specific gravity within the min and the max values listed per model)

MODEL NUMBER CODE AND MATERIALS OF CONSTRUCTION

| Model No. | Set points | Process /Tank connection | Float and trim | Magnetic sleeve |
|-----------|-----------------|--------------------------|------------------|------------------|
| T21-A | 2- Tandem float | Carbon steel | 316 SST (1.4401) | 400 series SST |
| T21-B | | | | 316 SST (1.4401) |
| T21-D | | 316 SST (1.4401) | | 316 SST (1.4401) |

Important: Actuating level, in either the rising or falling state, and specific gravity must be provided upon placement of order. The maximum available actuating level is governed by the liquid specific gravity and selected float size as given in the table below. The minimum actuating level is 102 mm (4 inches). The minimum distance between the top and bottom actuating levels is 203 mm (8 inches).

FLOAT SELECTION AND MAX ACTUATING LEVEL ^①

| Liquid Specific Gravity | Float Size mm (inches) | | | | | |
|-------------------------|------------------------|-----------|------------|-----------|----------------|-----------|
| | Ø 76 x 127 (3" x 5") | | Ø 102 (4") | | Ø 114 (4 1/2") | |
| | Upper | Lower | Upper | Lower | Upper | Lower |
| 1,00 | 533 (21) | 1219 (48) | 813 (32) | 1219 (48) | 1016 (40) | 1219 (48) |
| 0,90 | 229 (9) | 762 (30) | 457 (18) | 1118 (44) | 1016 (40) | 1219 (48) |
| 0,80 | — | — | 102 (4) | 533 (21) | 1016 (40) | 1219 (48) |
| 0,70 | — | — | — | — | 533 (21) | 1219 (48) |

^① The minimum actuating level is 102 mm (4"). The minimum distance between the top and bottom actuating levels is 203 mm (8").

FLOAT PRESSURE RATINGS

| Float Size mm (inches) | Pressure Rating bar (PSIG) | | | |
|------------------------|----------------------------|-----------------|------------------------------|-------------------------------|
| | 40 °C (100 °F) | 400 °C (750 °F) | 480 °C ^① (900 °F) | 540 °C ^① (1000 °F) |
| Ø 76 x 127 (3" x 5") | 34,4 (500) | 26,0 (377) | 24,3 (353) | 23,1 (335) |
| Ø 102 (4") | 41,3 (600) | 33,3 (483) | 32,0 (465) | 31,6 (459) |
| Ø 114 (4 1/2") | 34,4 (500) | 27,7 (403) | 26,7 (388) | 26,4 (383) |

^① Upon prolonged exposure to temperatures above 425 °C (800 °F), the carbide phase of steel may be converted to graphite. Permissible but not recommended for prolonged use above 425 °C (800 °F). (Applies to models T20-A & T20-B.)

TANK CONNECTION AND FLOAT SIZE

| Tank Connection | Float sizes | | |
|---------------------------------------|-------------------------|---------------|-------------------|
| | Ø 76 x 127 mm (3" x 5") | Ø 102 mm (4") | Ø 114 mm (4 1/2") |
| ASME Flanges ^① | | | |
| 4" 150 lbs RF | H3A | — | — |
| 4" 300 lbs RF | H4A | — | — |
| 5" 150 lbs RF | J3A | J3B | J3C ^② |
| 5" 300 lbs RF | J4A | J4B | J4C ^② |
| 6" 150 lbs RF | K3A | K3B | K3C |
| 6" 300 lbs RF | K4A | K4B | K4C |
| 8" 150 lbs RF | L3A | L3B | L3C |
| EN 1092-1 flanges ^① | | | |
| DN 100 PN16, Type B1 | 8FA | — | — |
| DN 100 PN 25/40, Type B1 | 8GA | — | — |
| DN 150 PN16, Type B1 | 9FA | 9FB | 9FC |
| DN 150 PN 25/40, Type B1 | 9GA | 9GB | 9GC |

^① Flanges are threaded onto 1" NPT bushing
^② Float cannot pass S160 nozzle or greater

SWITCH MECHANISM & HOUSING (next page)

T 2 1 complete order code for T21 models

X = product with a specific customer requirement

SELECT ELECTRIC SWITCH MECHANISM & HOUSING

| Switch Description | Process Temperature Range °C (°F) | Contacts | T21-A Models | | | | | | | | | | T21-B and T21-D Models | | | | | | | |
|---|---|----------|-----------------------|----------------------|----------|-----------------------|----------|-----------------------|-----------------------|----------------------|---------|------------------------|------------------------|----------------------|---------|-----------------------|-----------------------|----------------|-----|------------------------|
| | | | Weather proof (IP 66) | ATEX - IECEx (IP 66) | | | | | | | | FM (IP 66) NEMA 7/9 | Weather proof (IP 66) | ATEX - IECEx (IP 66) | | | | | | FM (IP 66) NEMA 7/9 |
| | | | | II 2G Ex d IIC T6 Gb | | | | II 1G Ex ia IIC T6 Ga | | | | | | II 2G Ex d IIC T6 Gb | | | II 1G Ex ia IIC T6 Ga | | | |
| | | | | Cast Aluminium | | Cast Iron (ATEX only) | | Cast Aluminium | | Cast Alu. | | | | Cast Aluminium | | Cast Iron (ATEX only) | | Cast Aluminium | | |
| M20x1,5 | 1" NPT | M20x1,5 | 1" NPT | M20x1,5 | 3/4" NPT | M20x1,5 | 1" NPT | 1" NPT | M20x1,5 | 1" NPT | M20x1,5 | 1" NPT | M20x1,5 | 3/4" NPT | M20x1,5 | 1" NPT | 1" NPT | | | |
| Series B Snap switch | -40 to +120 (-40 to +250) | 2x SPDT | B4A | BBA | BLC | BDC | BL7 | BV7 | - | - | BLA | B4B | BBB | BL9 | BD9 | BL5 | BV5 | - | - | BLB |
| | | 2x DPDT | B1A | BEA | BPC | BGC | BO7 | BY7 | - | - | BOA | B1B | BEB | BP9 | BG9 | BO5 | BY5 | - | - | BOB |
| Series C Snap switch | -40 to +230 (-40 to +450) | 2x SPDT | C4A | CBA | CLC | CDC | CL7 | CV7 | C4X | CBX | CLA | C4B | CBB | CL9 | CD9 | CL5 | CV5 | C4T | CBT | CLB |
| | | 2x DPDT | C1A | CEA | CPC | CGC | CO7 | CY7 | C1X | CEX | COA | C1B | CEB | CP9 | CG9 | CO5 | CY5 | C1T | CET | COB |
| Series D DC Current Snap switch | -40 to +120 (-40 to +250) | 2x SPDT | D4B | DBB | DL9 | DD9 | DL5 | DV5 | - | - | DLB | D4B | DBB | DL9 | DD9 | DL5 | DV5 | - | - | DLB |
| | | 2x DPDT | D1B | DEB | DP9 | DG9 | DO5 | DY5 | - | - | DOB | D1B | DEB | DP9 | DG9 | DO5 | DY5 | - | - | DOB |
| Series F Hermetically sealed Snap switch | -45 to +400 (-50 to +750) | 2x SPDT | FFA | FBA | FLC | FDC | FL7 | FV7 | - | - | FLA | FFB | FBB | FL9 | FD9 | FL5 | FV5 | - | - | FLB |
| | | 2x DPDT | FHA | FEA | FPC | FGC | FO7 | FY7 | - | - | FOA | FHB | FEB | FP9 | FG9 | FO5 | FY5 | - | - | FOB |
| Series U Gold alloy contacts Snap switch | -40 to +120 (-40 to +250) | 2x SPDT | U4A | UBA | ULC | UDC | UL7 | UV7 | U4X | UBX | ULA | U4B | UBB | UL9 | UD9 | UL5 | UV5 | U4T | UBT | ULB |
| | | 2x DPDT | U1A | UEA | UPC | UGC | UO7 | UY7 | U1X | UEX | UOA | U1B | UEB | UP9 | UG9 | UO5 | UY5 | U1T | UET | UOB |
| Series W Hermetically sealed Silver plated contacts Snap switch | -45 to +230 (-50 to +450) | 2x SPDT | W4A | WBA | WLC | WDC | WL7 | WV7 | W4X | WBX | WLA | W4B | WBB | WL9 | WD9 | WL5 | WV5 | W4T | WBT | WLB |
| | | 2x DPDT | W1B | WEB | WP9 | WG9 | WO5 | WY5 | W1T | WET | WOB | W1B | WEB | WP9 | WG9 | WO5 | WY5 | W1T | WET | WOB |
| Series X Hermetically sealed Gold plated contacts Snap switch | -45 to +230 (-50 to +450) | 2x SPDT | X4A | XBA | XLC | XDC | XL7 | XV7 | X4X | XBX | XLA | X4B | XBB | XL9 | XD9 | XL5 | XV5 | X4T | XBT | XLB |
| | | 2x DPDT | X1B | XEB | XP9 | XG9 | XO5 | XY5 | X1T | XET | XOB | X1B | XEB | XP9 | XG9 | XO5 | XY5 | X1T | XET | XOB |
| Series R High temperature Snap switch | -40 to +400 (-40 to +750) | 2x SPDT | R4B | R3B | RL9 | RD9 | RL5 | RV5 | - | - | RLB | R4B | R3B | RL9 | RD9 | RL5 | RV5 | - | - | RLB |
| | | 2x DPDT | RHB | REB | RP9 | RG9 | RO5 | RG5 | - | - | ROB | RHB | REB | RP9 | RG9 | RO5 | RG5 | - | - | ROB |
| Series 8 Hermetically sealed Snap switch | -45 to +400 (-50 to +750) | 2x SPDT | 84A | 8BA | 8LC | 8DC | 8L7 | 8V7 | - | - | 8LA | 84B | 8BB | 8L9 | 8D9 | 8L5 | 8V5 | - | - | 8LB |
| | | 2x DPDT | 81A | 8EA | 8PC | 8GC | 8O7 | 8Y7 | - | - | 8OA | 81B | 8EB | 8P9 | 8G9 | 8O5 | 8Y5 | - | - | 8OB |
| Series 9 High temperature Hermetically sealed Snap switch | -45 to +400 (-50 to +750) | 2x SPDT | 94A | 9BA | 9LC | 9DC | 9L7 | 9V7 | - | - | 9LA | 94B | 9BB | 9L9 | 9D9 | 9L5 | 9V5 | - | - | 9LB |
| | | 2x DPDT | 91A | 9EA | 9PC | 9GC | 9O7 | 9Y7 | - | - | 9OA | 91B | 9EB | 9P9 | 9G9 | 9O5 | 9Y5 | - | - | 9OB |
| Switch Description | Process Temperature Range °C (°F) | Contacts | Weather proof (IP 65) | ATEX (IP 66) | | | | | Weather proof (IP 65) | ATEX (IP 66) | | | | | | | | | | |
| | | | | II 2G Ex d IIC T6 Gb | | | | | | II 2G Ex d IIC T6 Gb | | | | | | | | | | |
| | | | | CS/Aluminium | | Cast Iron | | | | CS/Aluminium | | Cast Iron | | | | | | | | |
| | | | | 3/4" NPT | M20x1,5 | 3/4" NPT | 3/4" NPT | M20x1,5 | | 3/4" NPT | M20x1,5 | 3/4" NPT | | | | | | | | |
| Series R High temperature Snap switch | -40 to +540 ^② (-40 to +1000) | 2x SPDT | R3M | RL5 | RV5 | R3M | RL5 | RV5 | | | | | | | | | | | | |
| | | 2x DPDT | REM | RO5 | RG5 | REM | RO5 | RG5 | | | | | | | | | | | | |
| Series 9 High temperature Hermetically sealed Snap switch | -40 to +540 ^② (-40 to +1000) | 2x SPDT | 9BD | 9L7 | 9V7 | 9BM | 9L5 | 9V5 | | | | | | | | | | | | |
| | | 2x DPDT | 9ED | 9O7 | 9Y7 | 9EM | 9O5 | 9Y5 | | | | | | | | | | | | |

① Process temperature based on max. 40 °C (100 °F) ambient temperature and for non steam applications.

② Upon prolonged exposure to temperatures above 425 °C (800 °F), the carbide phase of steel may be converted to graphite. Permissible but not recommended for prolonged use above 425 °C (800 °F). (Applies to models T20-A & T20-B.)

PHYSICAL SPECIFICATIONS

| Description | | Specification |
|--|--------------------------------------|--|
| Measured variable | | Liquid level / interface level |
| Physical range | | Standard models: min S.G. 0,60 (T20) – 0,70 (T21) |
| Process temperature Process pressure (for higher ratings consult factory) | ø 76 x 127 mm (3" x 5") float | Up to 34,5 bar (500 psi) @ 40 °C (100 °F) Up to 540 °C (1000 °F) @ 23,1 bar (335 psi) |
| | ø 89 x 152 mm (3 1/2" x 6") float | Up to 34,5 bar (500 psi) @ 40 °C (100 °F) Up to 540 °C (1000 °F) @ 26,4 bar (383 psi) |
| | ø 102 mm (4") float | Up to 41,3 bar (600 psi) @ 40 °C (100 °F) Up to 540 °C (1000 °F) @ 31,6 bar (459 psi) |
| | ø 114 mm (4 1/2") float | Up to 34,5 bar (500 psi) @ 40 °C (100 °F) Up to 540 °C (1000 °F) @ 26,4 bar (383 psi) |
| Process connection material | | carbon steel or stainless steel (others at request) |
| Wetted materials | Float and trim | 316 SST (1.4401) |
| | Magnetic sleeve | 316 SST (1.4401) or 400 series SST |

ELECTRICAL SPECIFICATIONS

| Description | Specification |
|------------------------------------|---|
| Switch ratings | Up to 15 A @ 240 V AC (depending on switch mechanism) Up to 10 A @ 120 V DC (depending on switch mechanism) |
| Signal output | Single, dual or triple SPDT or DPDT contacts or single pneumatic |
| Switch types (see table on page 4) | Dry contact with standard or gold alloy contacts, Hermetically sealed, Hermetically sealed with gold or silver plated contacts, Proximity switch, or single pneumatic bleed and non bleed |

ELECTRICAL CONNECTION

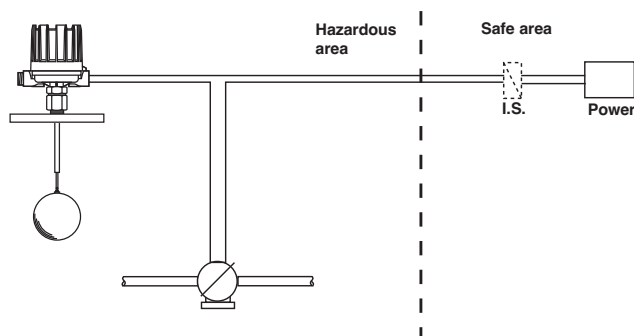
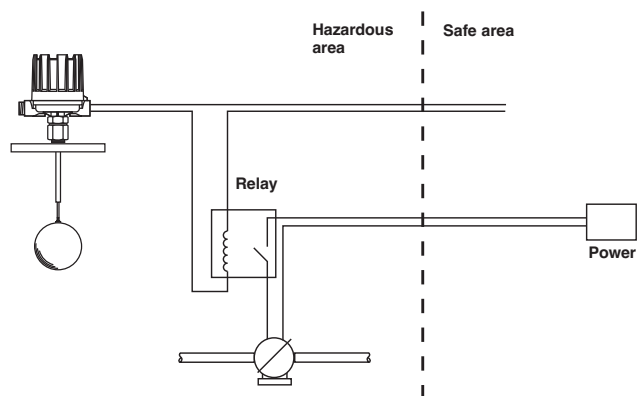



QUALITY ASSURANCE - ISO 9001

THE QUALITY ASSURANCE SYSTEM IN PLACE AT MAGNETROL GUARANTEES THE HIGHEST LEVEL OF QUALITY DURING THE DESIGN, THE CONSTRUCTION AND THE SERVICE OF CONTROLS. OUR QUALITY ASSURANCE SYSTEM IS APPROVED AND CERTIFIED TO **ISO 9001** AND OUR TOTAL COMPANY IS COMMITTED TO PROVIDING FULL CUSTOMER SATISFACTION BOTH IN QUALITY PRODUCTS AND QUALITY SERVICE.

PRODUCT WARRANTY

ALL MAGNETROL MECHANICAL LEVEL CONTROLS ARE WARRANTED FREE OF DEFECTS IN MATERIALS AND WORKMANSHIP FOR FIVE FULL YEARS FROM THE DATE OF ORIGINAL FACTORY SHIPMENT.

IF RETURNED WITHIN THE WARRANTY PERIOD; AND, UPON FACTORY INSPECTION OF THE CONTROL, THE CAUSE OF THE CLAIM IS DETERMINED TO BE COVERED UNDER THE WARRANTY; THEN, MAGNETROL INTERNATIONAL WILL REPAIR OR REPLACE THE CONTROL AT NO COST TO THE PURCHASER (OR OWNER) OTHER THAN TRANSPORTATION.

MAGNETROL SHALL NOT BE LIABLE FOR MISAPPLICATION, LABOR CLAIMS, DIRECT OR CONSEQUENTIAL DAMAGE OR EXPENSE ARISING FROM THE INSTALLATION OR USE OF THE EQUIPMENT. THERE ARE NO OTHER WARRANTIES EXPRESSED OR IMPLIED, EXCEPT, SPECIAL WRITTEN WARRANTIES COVERING SOME MAGNETROL PRODUCTS.

UNDER RESERVE OF MODIFICATIONS

BULLETIN: BE 44-117.9
EFFECTIVE: OCTOBER 2019
SUPERSEDES: April 2018

European Headquarters & Manufacturing Facility

Heikensstraat 6

9240 Zele, Belgium

Tel: +32-(0)52-45.11.11 • Fax: +32-(0)52-45.09.93

e-mail: info@magnetrol.be

www.magnetrol.com

