



SAF1-YL



SAF Pump with Stand and Winch  
(Drum Supplied by Lubricant Supplier)

These pneumatic barrel pumps, SAF1-YL with one outlet and SAF2-YL with two outlets are designed for use in spray systems for the supply of adhesive lubricants (NLGI 0 and 00). SAF pumps are placed directly into 200 liter drums. They do not require a follower plate, thus the supply of lubricant is possible even if the drum is severely dented. With the aid of an optional stand and winch unit, it is easy to exchange barrels.

## Models

Part No.	Description	Number of Outlets	Lubricant Output/Stroke	Low-level
615-26392-3	SAF1-YN	1	1.1 cm <sup>3</sup> (0.067 in <sup>3</sup> )	no
615-26393-4	SAF1-YL	1	1.1 cm <sup>3</sup> (0.067 in <sup>3</sup> )	yes
615-26394-3	SAF2-YN	2	2 x 1.1 cm <sup>3</sup> (2 x 0.067 in <sup>3</sup> )	no
615-26395-4	SAF2-YL	2	2 x 1.1 cm <sup>3</sup> (2 x 0.067 in <sup>3</sup> )	yes

## Technical Data

maximum operating pressure	300 bar (4350 psi)
driving pressure	minimum 4 bar (58 psi) maximum 10 bar (145 psi)
air inlet connection	1/4 NPT female
pneumatic drive ratio	40:1
sound level	< 70 dB(A)
lubricant outlet	G 1/4 f (BSPP)
drum type	for 200 l lidded barrels acc. to DIN 6644
dimensions (L x W x H)	610 x 610 x 985 mm (24 x 24 x 38.8 in)

Note: A 3/2 way air solenoid valve is required.

## Accessories

Part No.	Description
615-26739-1	stand with winch for SAF1 (1 pinion drive) with air maintenance unit (FLR), pressure relief valve, air hoses and lubricant hoses
615-26740-1	stand with winch for SAF2 (2 pinion drive) with air maintenance unit (FLR), 2 pressure relief valves, air hoses and lubricant hoses
515-30955-1	overpressure valve (120 bar) manifold with pressure gauge

# Example: Stand with Winch for SAF2

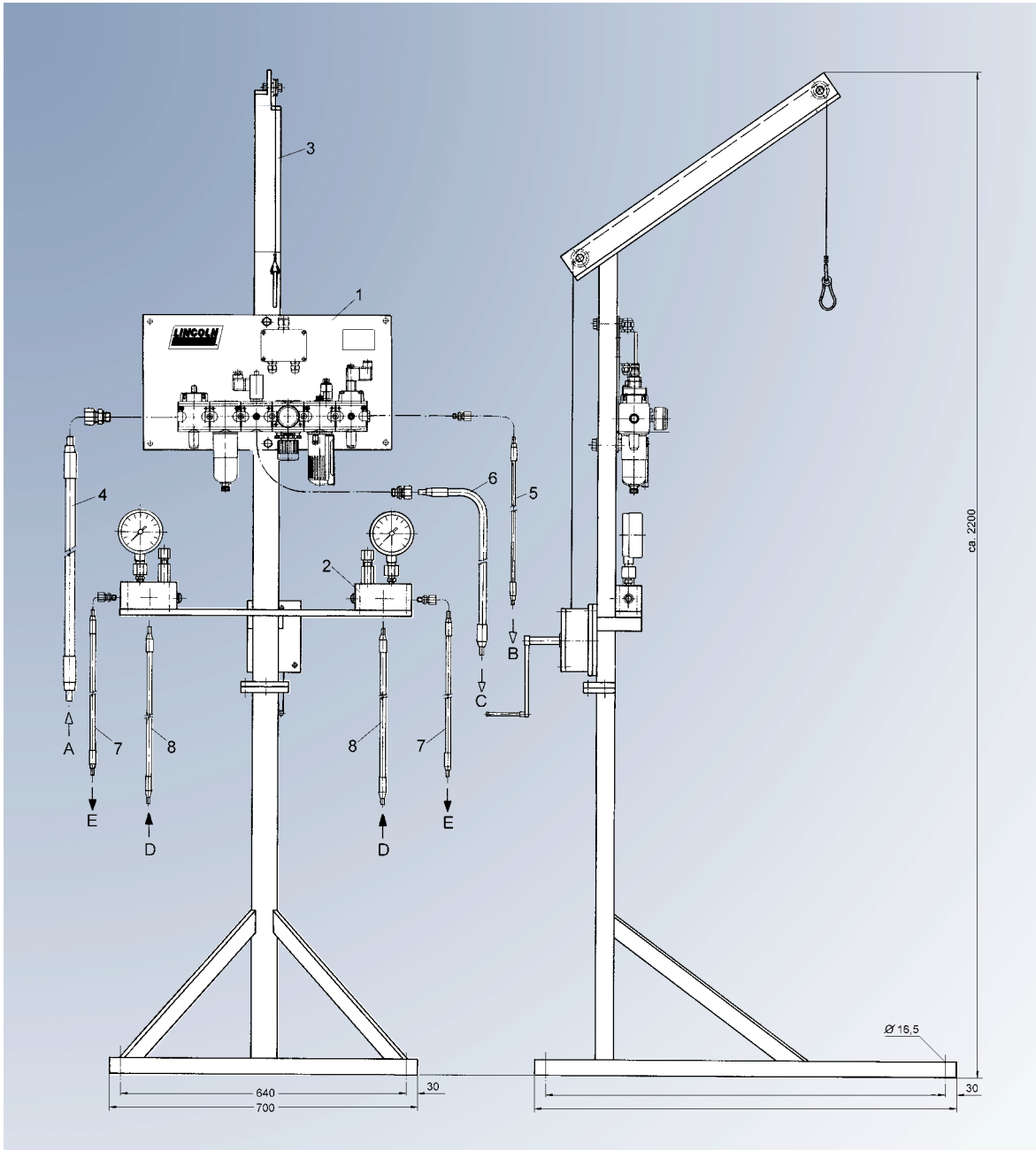

Dimensions (L x W x H): 950 x 700 x 2200 mm (37.4 x 27.6 x 86.6 in)

## Item Designation

- A compressed air from compressor
- B compressed air to pump
- C compressed air to spray unit
- D lubricant from pump
- E lubricant to spray unit

## Item Designation

- 1 maintenance unit
- 2 pressure relief device HSA-TD21
- 3 stand with winch
- 4 low-pressure hose OD 16 x 1040 mm with 20 mm stud
- 5 high-pressure hose OD 6 x 1540 mm with 10 mm stud
- 6 low-pressure hose OD 13 x 1040 mm with 15 mm stud
- 7 high-pressure hose OD 8 x 1040 mm with 10 mm stud
- 8 high-pressure hose OD 8 x 1540 mm with 10 mm stud