



Pneumatické rozprašovací trysky

Plný kužel, tlakový princip, vnitřní směšování

Série 136.2



Jemné rozprašování ve formě plného kužele pomocí vzduchu nebo plynu. Obzvláště velký úhel rozstřiku od 60°. Princip přívodu kapaliny pod tlakem. Vnitřní směšování médií.
 Aplikace: zvlhčování vzduchu, chlazení

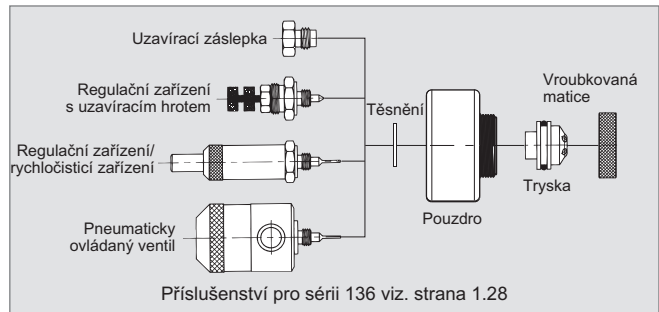
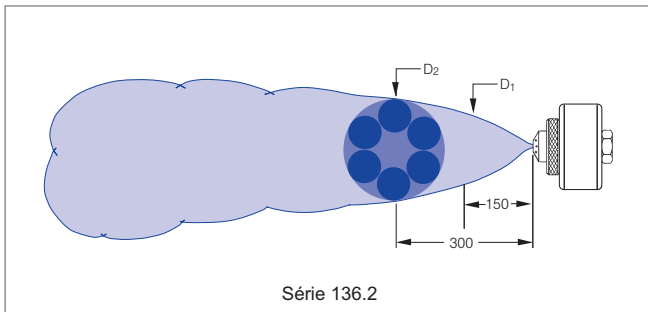
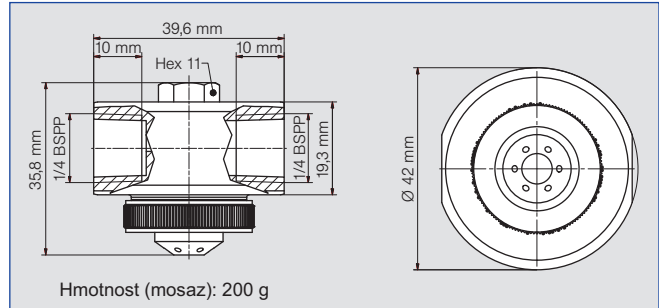

Úhel rozstřiku	Objednací číslo		E Ø [mm]	Tlak kapaliny p [bar]												Rozměry paprsku				
	Typ	č. materiálu		0.7			1.5			3.0			4.0			p Vzduch [bar]	p Voda [bar]	D1 [mm]	D2 [mm]	
				p Vzduch [bar]	V Voda [l/h]	Vn Vzduch [m³/h]	p Vzduch [bar]	V Voda [l/h]	Vn Vzduch [m³/h]	p Vzduch [bar]	V Voda [l/h]	Vn Vzduch [m³/h]	p Vzduch [bar]	V Voda [l/h]	Vn Vzduch [m³/h]					
60°	136. 215. xx. A2	○ ○	0.5	1.00	3.00	1.30	1.60	5.80	1.70	2.80	8.50	2.40	3.80	9.40	3.10	1.00	0.70	200	330	
				1.20	1.80	1.50	1.80	4.90	1.90	3.20	7.20	2.80	4.20	8.20	3.50	1.60	1.50	230	380	
				1.40	0.70	1.80	2.00	3.80	2.10	3.60	5.70	3.20	4.60	6.90	3.90	2.40	2.00	230	385	
				-	-	-	2.20	2.80	2.30	4.00	4.00	3.60	5.00	5.40	4.20	3.20	3.00	245	390	
				-	-	-	2.40	1.70	2.50	4.40	2.20	4.10	5.40	3.80	4.70	4.20	4.00	250	410	
				-	-	-	2.60	0.80	2.80	4.80	0.80	4.50	5.80	2.30	5.20	-	-	-	-	-
	136. 222. xx. A2	○ ○	1.0	0.80	17.50	2.80	1.60	25.90	4.00	3.00	40.40	5.80	3.80	54.90	6.40	0.80	0.70	250	450	
				1.00	6.00	4.30	1.80	14.70	5.30	3.20	31.50	6.90	4.00	45.60	7.30	1.60	1.50	245	465	
				-	-	-	2.00	6.70	6.70	3.40	22.20	8.20	4.20	37.60	8.50	2.30	2.00	245	465	
				-	-	-	2.20	1.90	8.10	3.60	14.60	9.50	4.40	29.60	9.70	3.20	3.00	250	465	
				-	-	-	-	-	-	-	3.80	8.50	11.00	4.60	21.60	11.20	4.20	4.00	245	465
				-	-	-	-	-	-	-	4.00	4.50	12.30	4.80	15.30	12.40	-	-	-	-
136. 231. xx. A2	○ ○	1.4	1.60	25.60	5.10	2.60	44.20	7.00	3.60	93.70	7.90	4.20	132.90	7.30	2.00	0.70	235	380		
			2.00	17.80	6.20	3.00	33.00	8.20	4.00	78.30	9.30	4.60	117.20	9.00	2.60	1.50	245	415		
			2.40	11.30	7.20	3.40	24.70	9.20	4.40	65.80	10.60	5.00	101.10	10.40	2.40	2.00	255	420		
			2.80	6.90	8.10	3.80	18.10	10.20	4.80	54.90	11.90	5.40	87.90	11.80	3.60	3.00	255	425		
			-	-	-	4.20	13.20	11.20	5.20	45.60	13.00	5.80	76.60	13.20	4.20	4.00	265	430		
			-	-	-	4.60	9.30	12.00	5.60	38.00	14.10	6.00	71.20	13.80	-	-	-	-	-	

E = nejužší průřez (pro vodu)

Příklad Typ + Č. materiálu (xx) = Objednací číslo
 objednání 136. 215. xx. A2 + 1Y = 136. 215. 1Y. A2

